



View this document in HTML
crestron.com/docs/9243



Horizon® 2 Dimmers, Switches, and Keypads

Custom Engravable In-Wall Dimmers,
Switches, Keypads, and Accessories

Product Manual

The original language version of this document is U.S. English.
All other languages are a translation of the original document.

Regulatory Model: M201849001, M201849002, M201849003, M201849004, M201849005, M201849006, M201849007

Crestron product development software is licensed to Crestron dealers and Crestron Service Providers (CSPs) under a limited nonexclusive, nontransferable Software Development Tools License Agreement. Crestron product operating system software is licensed to Crestron dealers, CSPs, and end-users under a separate End-User License Agreement. Both of these Agreements can be found on the Crestron website at www.crestron.com/legal/software_license_agreement.

The product warranty can be found at www.crestron.com/warranty.

The specific patents that cover Crestron products are listed online at www.crestron.com/legal/patents.

Certain Crestron products contain open source software. For specific information, please visit www.crestron.com/opensource.

Crestron, the Crestron logo, Cresnet, Crestron Home, Crestron Toolbox, Horizon, and infiNET EX are either trademarks or registered trademarks of Crestron Electronics, Inc. in the United States and/or other countries. SolaHD and SDP are either a trademark or registered trademark of APPLETON GRP LLC in the United States and/or other countries. Other trademarks, registered trademarks, and trade names may be used in this document to refer to either the entities claiming the marks and names or their products. Crestron disclaims any proprietary interest in the marks and names of others. Crestron is not responsible for errors in typography or photography.

Crestron, the Crestron logo, Cresnet, and Horizon are either trademarks or registered trademarks of Crestron Electronics, Inc. in the United States and/or other countries. Other trademarks, registered trademarks, and trade names may be used in this document to refer to either the entities claiming the marks and names or their products. Crestron disclaims any proprietary interest in the marks and names of others. Crestron is not responsible for errors in typography or photography.

Crestron, the Crestron logo, and Horizon are either trademarks or registered trademarks of Crestron Electronics, Inc. in the United States and/or other countries. Other trademarks, registered trademarks, and trade names may be used in this document to refer to either the entities claiming the marks and names or their products. Crestron disclaims any proprietary interest in the marks and names of others. Crestron is not responsible for errors in typography or photography.

infiNET EX 

©2024 Crestron Electronics, Inc.

Contents

- Overview 7**
- Horizon® 2 Devices Common Features 8
 - Button and Color Options 8
 - Multigang Expansion with Horizon® 2 Faceplates 11
 - Multiway Control 11
 - Standard Wall Mount 12
 - Communications 12
 - Cresnet® Wired Communications 12
- Feature Comparison 13
 - Features 13
 - Load Types 13
- HZ2-DIMEX Features 15
- HZ2-DIMLVEX Features 18
- HZ2-DIMUEX Features 21
 - Universal Phase Dimming 23
- HZ2-SWEX Features 24
- HZ2-KPEX Features 27
- HZ2-KPCN Features 30
- HZ2-AUX Features 33
 - Multiway Dimming and Switching 34
- HZ2A-KEY Features 36
- HZ2-BTNS Features 37
- HZ2-FP-G Features 39
- Specifications 43**
- HZ2-DIMEX Specifications 44
 - Product Specifications 44
 - Dimension Drawings 47
- HZ2-DIMLVEX Specifications 48
 - Product Specifications 48
 - Dimension Drawings 51
- HZ2-DIMUEX Specifications 52
 - Product Specifications 52
 - Dimension Drawings 55
- HZ2-SWEX Specifications 56
 - Product Specifications 56
 - Dimension Drawings 58
- HZ2-KPEX Specifications 59
 - Product Specifications 59
 - Dimension Drawings 61
- HZ2-KPCN Specifications 62
 - Product Specifications 62

Dimension Drawings	64
HZ2-AUX Specifications	65
Product Specifications	65
Dimension Drawings	67
HZ2A-KEY Specifications	68
Product Specifications	68
Dimension Drawings	69
HZ2-FP-G Specifications	70
Product Specifications	70
Dimension Drawings	71
Installation	80
In the Box	81
Keypads	81
Faceplates	82
Mounting	86
Horizon 2 Line Voltage Devices and Multi-Gang Installation	86
HZ2-KPCN Mounting	98
HZ2-KPCN Mounting in an EU Backbox	105
HZ2A-KEY Mounting	107
Post-Installation Metal Backplate Assembly	111
Multi-Gang Derating	112
Wiring	115
Line Powered Devices	115
24VDC Powered Devices	117
Button Assemblies	118
Replace Button Assemblies	118
Local Button Functions	119
Multiway Control from Remote Device	120
Configuration	121
Disconnect Power Locally	122
Backlight Color Theme	123
Ambient Light Sensor Calibration	124
Dimming Mode	125
HZ2-DIMEX	125
HZ2-DIMUEX	125
Wireless Communications	127
Joining an infiNET EX Network	127
Leaving an infiNET EX Network	128
Verifying Communications Status	128
Demo Mode	129
Entering and Exiting	129
Demo Mode Options	129
Troubleshooting	131

Resources	134
Crestron Support and Training	134
Programmer and Developer Resources	134
Product Certificates	134

Overview

Horizon® 2 keypads, dimmers, and switches are custom engravable luxury keypads that provide in-wall control of a variety of lighting load types and 1/2 HP motors. The entire line of Horizon® 2 devices are finished with Horizon® 2 faceplates to provide a consistent look and feel, making them a great addition to new or retrofit installations. Horizon 2 keypads, dimmers, and switches are available with default engraving or custom engraving.

These Horizon® 2 devices are available:

- HZ2-DIMEX - Forward-Phase Dimmer with infiNET EX® Wireless Communication
- HZ2-DIMLVEX - 0-10V Dimmer with infiNET EX® Wireless Communication
- HZ2-DIMUEX - Universal Phase Dimmer with infiNET EX® Wireless Communication
- HZ2-KPEX - Keypad with infiNET EX® Wireless Communication
- HZ2-KPCN - Keypad with Cresnet® Wired Communication
- HZ2-SWEX - Switch with infiNET EX® Wireless Communication
- HZ2-BTNS - Style 1, 2, 3, 4, 5, and 6 Button Trees for Keypads, Dimmers, and Switches
- HZ2-AUX - Multi-Way Remote
- HZ2A-KEY - 1, 2, and 4 Aperture Keystone Plate
- HZ2-FP-G - 1, 2, 3, and 4-Gang Faceplates for Horizon® 2 Devices

Horizon® 2 products are available in white (-W), almond (-A), black (-B), white glass (-GLASS-W), and black glass (-GLASS-B).

For additional information about the Horizon® 2 product line, refer to [Features](#) and [Specifications on page 43](#).

This section provides the following information:

- [Horizon® 2 Devices Common Features](#)
- [Feature Comparison](#)
- [HZ2-DIMEX Features](#)
- [HZ2-DIMLVEX Features](#)
- [HZ2-DIMUEX Features](#)
- [HZ2-SWEX Features](#)
- [HZ2-KPEX Features](#)
- [HZ2-KPCN Features](#)
- [HZ2-AUX Features](#)
- [HZ2A-KEY Features](#)
- [HZ2-BTNS Features](#)
- [HZ2-FP-G Features](#)

Horizon® 2 Devices Common Features

The features described below are common for all Horizon® 2 devices except where noted.

Button and Color Options

NOTE: The HZ2-AUX does not support Integrated Keypad, Multicolor Backlit Button Assemblies, and infiNET EX wireless or Cresnet wired communications.

Integrated Keypad

Supporting up to five buttons in six available button configurations, the HZ2-DIMUEX is configurable for a variety of applications. When connected to the Crestron network, the keypad can trigger remote actions.

Button Assembly Engraving

Functions of each button on the button assembly can be identified with custom, laser-etched engraving. Engraved buttons can be illuminated using the device's LED backlights. Engraving is included with ENGRAVED models. Standard button assemblies without engraving (BLANK models) are also available and can be used as is or can be custom engraved by a third-party engraver.

NOTE: Glass Horizon 2 buttons can only be engraved by Crestron and are not offered blank.

When a custom engraved model is ordered, the engraved button assembly is installed on the device before it is shipped. Engraving files must be provided at time of order and can be created using [Impress Custom Engraving Software](#), the Crestron Home® Setup app, the Crestron Home Online Configurator, or D3Pro® software. Create engraving files using [Impress Custom Engraving Software](#), the Crestron Home® Setup app, the Crestron Home Online Configurator, or D3Pro® software. If necessary, custom engraving can be changed until the order is processed by emailing orders@crestron.com with the updated engraving file and order information.

To order replacement engravings, refer to the [HZ2-BTNS ENGRAVED](#) button assembly product page.

Multicolor Backlit Button Assemblies

The engraved buttons are illuminated using the device's RGB LED backlights. Each button can be assigned custom color backlighting. The LED backlight provides feedback by changing the intensity, changing the color, or flashing to show that an action is being performed. Backlighting colors can be adjusted using Crestron Home software or other Crestron programming tools.

Local color theme sets the colors for all buttons on the device. In addition to the local color theme, each button can be assigned an alternate color theme. Thirteen local color themes are available that include Tunable White (default is Warm White), Neutral White, Cool White, and a variety of common colors. The local color theme and alternate color themes can be changed programmatically.

Field-Replaceable Button Assemblies

The field-replaceable button assemblies allow for changes in device function or to allow the customer to use the system before finalizing the engravings. The button assembly can be replaced with custom engraving (ENGRAVED models) or no engraving (BLANK models).

HZ2-BTNS-1 (Style 1), White (-W), Black (-B), and Almond (-A):

5 single buttons



HZ2-BTNS-2 (Style 2), White (-W), Black (-B), and Almond (-A):

4 single buttons and 1 split rocker button;
Split rocker button is located in the lowest button position



HZ2-BTNS-1-W ENGRAVED with Custom Engraving



HZ2-BTNS-2-W ENGRAVED with Custom Engraving



HZ2-BTNS-3 (Style 3), White (-W), Black (-B), and Almond (-A):

4 single buttons and 1 split rocker button;
Split rocker button is located in the second lowest button position



HZ2-BTNS-4 (Style 4), White (-W), Black (-B), and Almond (-A):

3 single buttons and 2 split rocker buttons;
Split rocker buttons are located in the two lowest button positions



HZ2-BTNS-3-W ENGRAVED with Custom Engraving



HZ2-BTNS-4-W ENGRAVED with Custom Engraving



HZ2-BTNS-5 (Style 5), White (-W), Black (-B), and Almond (-A):

1 medium rocker button and 2 single buttons;
Single buttons are located in the two lowest button positions



HZ2-BTNS-5-W ENGRAVED with Custom Engraving



HZ2-BTNS-6 (Style 6), White (-W), Black (-B), and Almond (-A):

1 large rocker button



HZ2-BTNS-6-W ENGRAVED with Custom Engraving



Multigang Expansion with Horizon® 2 Faceplates

Install up to four Horizon® 2 devices side-by-side in a US multigang electrical box with a compatible [HZ2-FP-G](#) series faceplate. When multiple devices are installed in a 2-, 3-, or 4-gang faceplate, the buttons on the devices are aligned to form one continuous control surface.

Multiway Control

The HZ2-DIMUEX, HZ2-DIMEX, and HZ2-SWEX support load control from multiple locations. Up to four [HZ2-AUX](#) or [HZ2-KPEX](#) devices (sold separately) can be connected to a traveler wire in a traditional three- or four-way circuit to control an attached load. The HZ2-KPEX provides button backlights and six different engravable button assembly options while the HZ2-AUX provides no button backlight and only accommodates a single large rocker button assembly (Style 6).

Standard Wall Mount

Horizon keypads are designed for installation in a standard electrical wall box, making them perfect for installation in a multi-gang box alongside other Horizon devices.

Communications

infiNET EX® Wireless Communications

infiNET EX wireless technology provides two-way RF communications throughout a residential or commercial structure without the need for physical control wiring. Each infiNET EX device acts as an expander by sending command signals to other infiNET EX devices in range (approximately 150 ft (46 m) indoors) to ensure reliability and stability.

The device communicates with a control system via a [Crestron Wireless Gateway](#) (sold separately). Up to 100 infiNET EX devices may coexist on a wireless network.

NOTE: Any infiNET EX device that provides expander functionality will effectively extend the range of the wireless network beyond the initial range of the gateway. Battery-powered infiNET EX devices do not provide expander functionality. A dedicated infiNET EX Wireless Expander is also available ([CLW-EXPEX](#), sold separately).

Cresnet® Wired Communications

The keypad communicates with a Crestron control system via Cresnet, a 4-wire network bus that provides bidirectional data communication and 24VDC power to each keypad in the system. To simplify wiring in a multigang arrangement, the keypad includes dual parallel Cresnet ports for daisy-chaining.

Feature Comparison

The Horizon® 2 devices and their features are described below. For detailed information, refer to [Features](#) and [Specifications on page 43](#) for each device.

Features

	Ambient Light Sensor	Integrated Keypad	Engraving	Backlit Buttons	Field Replaceable Button Assemblies	Multiway Control	Wireless Control	Wired Control
HZ2-DIMEX	✓	✓	✓	✓	✓	✓	✓	
HZ2-DIMLVE X	✓	✓	✓	✓	✓		✓	
HZ2-DIMUEX	✓	✓	✓	✓	✓	✓	✓	
HZ2-KPEX	✓	✓	✓	✓	✓		✓	
HZ2-KPCN	✓	✓	✓	✓	✓			✓
HZ2-SWEX	✓	✓	✓	✓	✓	✓	✓	
HZ2-AUX			✓		✓*	✓		

* Only the HZ2-BTNS-6 (Style 6) button assembly is compatible.

Load Types

Device	Load Type
HZ2-DIMEX	Incandescent
	Magnetic Low Voltage
	Tungsten-Halogen
HZ2-DIMLVEX	0-10VDC Ballasts
	LED Drivers
HZ2-DIMUEX	Incandescent
	Magnetic Low Voltage
	LED
	Electronic Low Voltage

Device	Load Type
HZ2-SWEX	Incandescent
	Magnetic Low Voltage
	Tungsten-Halogen
	Electronic Low Voltage
	1/2 HP Motor

HZ2-DIMEX Features

The [HZ2-DIMEX](#) Horizon® 2 in-wall forward phase dimmer provides infiNET EX® wireless network control of incandescent, magnetic low voltage, and tungsten-halogen loads. Its design matches the entire line of Horizon dimmers, switches, and keypads, making it a great addition to new or retrofit installations.

The HZ2-DIMEX is available with default engraving on a rocker button assembly (Style 6) or custom engraving on any style button assembly.

- Default engraving on a rocker button assembly (Style 6) is provided with the HZ2-DIMEX-A, HZ2-DIMEX-W, HZ2-DIMEX-B, HZ2-DIMEX-GLASS-W, and HZ2-DIMEX-GLASS-B. The default engraving includes a simple dot to provide feedback and indicate where the button can be pressed.



- Custom engraving on any style button assembly is provided with the HZ2-DIMEX-A ENGRAVED, HZ2-DIMEX-W ENGRAVED, HZ2-DIMEX-B ENGRAVED, HZ2-DIMEX-GLASS-W ENGRAVED, and HZ2-DIMEX-GLASS-B ENGRAVED. The custom engraved button assembly is installed prior to shipment instead of the default engraved, default button assembly.



NOTE: Faceplates are not included. Refer to the [HZ2-FP-G series](#) faceplates for more information.

Key features include:

- Forward phase dimming
- Switching mode for nondimmable loads
- Supports multiway controllers that provide control using a traveler wire in a traditional three- or four-way circuit ([HZ2-AUX](#) and [HZ2-KPEX](#), sold separately)
- 1- to 4-gang U.S. wall box installation using Horizon® 2 multi-gang faceplates ([HZ2-FP-G series](#), sold separately)
- Robust infiNET EX® wireless communication
- Preinstalled large rocker button assembly (Style 6) with default engraving or can be configured with six different button assemblies with custom engraving
- Multicolor RGB LEDs provide backlighting for engraved buttons
- White LED backlighting is available and can be dynamically set anywhere between 2000K and 8000K
- Replacement button assemblies available in six styles to accommodate changes in device function or engravings
- Standard blank button assemblies available for engraving by a third-party

- Ambient light sensor for auto-dimming with separate day and night backlight modes
- Fully programmable via a Crestron control system
- Local button functionality for load control without programming
- Requires neutral wire connection
- Crestron Home® OS compatible
- Available in white, black, almond, white glass, and black glass
- Optionally mix standard and glass finishes

HZ2-DIMLVEX Features

The [HZ2-DIMLVEX](#) Horizon® 2 in-wall 0–10V dimmer and switch provides infiNET EX® wireless network control of 0–10V controlled ballasts and drivers. Its design matches the entire line of Horizon dimmers, switches, and keypads, making it a great addition to new or retrofit installations.

The HZ2-DIMLVEX is available with default engraving on a rocker button assembly (Style 6) or custom engraving on any style button assembly.

- Default engraving on a rocker button (Style 6) is provided with the HZ2-DIMLVEX-A, HZ2-DIMLVEX-W, HZ2-DIMLVEX-B, HZ2-DIMLVEX-GLASS-W, and HZ2-DIMLVEX-GLASS-B. The default engraving includes a simple dot to provide feedback and indicate where the button can be pressed.



- Custom engraving on any style button assembly is provided with the HZ2-DIMLVEX-A ENGRAVED, HZ2-DIMLVEX-W ENGRAVED, HZ2-DIMLVEX-B ENGRAVED, HZ2-DIMLVEX-GLASS-W ENGRAVED, and HZ2-DIMLVEX-GLASS-B ENGRAVED. The custom engraved button assembly is installed prior to shipment.



NOTE: Faceplates are not included. Refer to the [HZ2-FP-G series](#) faceplates for more information.

Key features include:

- 0-10V dimming control
- Integrated switch to cut load power
- 1- to 4-gang U.S. wall box installation using Horizon® 2 multi-gang faceplates ([HZ2-FP-G series](#), sold separately)
- Robust infiNET EX® wireless communication
- Preinstalled large rocker button assembly (Style 6) with default engraving or can be configured with six different button assemblies with custom engraving
- Multicolor RGB LEDs provide backlighting for engraved buttons
- White LED backlighting is available and can be dynamically set anywhere between 2000K and 8000K
- Replacement button assemblies available in six styles to accommodate changes in device function or engravings
- Standard blank button assemblies available for engraving by a third-party
- Ambient light sensor for auto-dimming with separate day and night backlight modes
- Fully programmable via a Crestron control system

- Local button functionality for load control without programming
- Requires neutral wire connection
- Crestron Home® OS compatible
- Available in white, black, almond, white glass, and black glass
- Optionally mix standard and glass finishes

HZ2-DIMUEX Features

The [HZ2-DIMUEX](#) Horizon® 2 in-wall universal phase dimmer provides infiNET EX® wireless network control of LED, incandescent, magnetic low voltage, and electronic low voltage loads. It has the ability to adjust minimum and maximum light levels and to set the dimming curve to be linear, logarithmic, or use a custom curve. Its design matches the entire line of Horizon dimmers, switches, and keypads, making it a great addition to new or retrofit installations.

The HZ2-DIMUEX is available with default engraving on a rocker button assembly (Style 6) or custom engraving on any style button assembly.

- Default engraving on a rocker button assembly (Style 6) is provided with the HZ2-DIMUEX-A, HZ2-DIMUEX-W, HZ2-DIMUEX-B, HZ2-DIMUEX-GLASS-W, and HZ2-DIMUEX-GLASS-B. The default engraving includes a simple dot to provide feedback and indicate where the button can be pressed.



- Custom engraving on any style button assembly is provided with the HZ2-DIMUEX-A ENGRAVED, HZ2-DIMUEX-W ENGRAVED, HZ2-DIMUEX-B ENGRAVED, HZ2-DIMUEX-GLASS-W ENGRAVED, and HZ2-DIMUEX-GLASS-B ENGRAVED. The custom engraved button assembly is installed prior to shipment instead of the default engraved, default button assembly.



NOTE: Faceplates are not included. Refer to the [HZ2-FP-G series](#) faceplates for more information.

Key features include:

- Universal dimming - reverse phase and forward phase - with auto load detection
- Over current protection
- Supports multiway controllers that provide control using a traveler wire in a traditional three- or four-way circuit ([HZ2-AUX](#) and [HZ2-KPEX](#), sold separately)
- 1- to 4-gang U.S. wall box installation using Horizon® 2 multi-gang faceplates ([HZ2-FP-G](#) series, sold separately)
- Robust infiNET EX® wireless communication
- Preinstalled large rocker button assembly (Style 6) with default engraving or can be configured with six different button assemblies with custom engraving
- Multicolor RGB LEDs provide backlighting for engraved buttons
- White LED backlighting is available and can be dynamically set anywhere between 2000K and 8000K
- Replacement button assemblies available in six styles to accommodate changes in device function or engravings
- Standard blank button assemblies available for engraving by a third-party

- Ambient light sensor for auto-dimming with separate day and night backlight modes
- Fully programmable via a Crestron control system
- Local button functionality for load control without programming
- Requires neutral wire connection
- Crestron Home® OS compatible
- Available in white, black, almond, white glass, and black glass
- Optionally mix standard and glass finishes

Universal Phase Dimming

The HZ2-DIMUEX features auto-load detection to automatically select the appropriate dimming method for the attached load. Auto-load detection allows for broad load type compatibility even if the load type is changed in the future.

HZ2-SWEX Features

The [HZ2-SWEX](#) Horizon® 2 in-wall switch provides infiNET EX® wireless network control of incandescent, magnetic low voltage, and tungsten-halogen loads as well as electronic ballasts and 1/2 HP motors. Its design matches the entire line of Horizon dimmers, switches, and keypads, making it a great addition to new or retrofit installations.

The HZ2-SWEX is available with default engraving on a rocker button assembly (Style 6) or custom engraving on any style button assembly.

- Default engraving on a rocker button assembly (Style 6) is provided with the HZ2-SWEX-A, HZ2-SWEX-W, HZ2-SWEX-B, HZ2-SWEX-GLASS-W, and HZ2-SWEX-GLASS-B. The default engraving includes a simple dot to provide feedback and indicate where the button can be pressed.



- Custom engraving on any style button assembly is provided with the HZ2-SWEX-A ENGRAVED, HZ2-SWEX-W ENGRAVED, HZ2-SWEX-B ENGRAVED, HZ2-SWEX-GLASS-W ENGRAVED, and HZ2-SWEX-GLASS-B ENGRAVED. The custom engraved button assembly is installed prior to shipment.



NOTE: Faceplates are not included. Refer to the [HZ2-FP-G series](#) faceplates for more information.

Key features include:

- Supports multiway controllers that provide control using a traveler wire in a traditional three- or four-way circuit ([HZ2-AUX](#) and [HZ2-KPEX](#), sold separately)
- 1- to 4-gang U.S. wall box installation using Horizon® 2 multi-gang faceplates ([HZ2-FP-G](#) series, sold separately)
- Robust infiNET EX® wireless communication
- Preinstalled large rocker button assembly (Style 6) with default engraving or can be configured with six different button assemblies with custom engraving
- Multicolor RGB LEDs provide backlighting for engraved buttons
- White LED backlighting is available and can be dynamically set anywhere between 2000K and 8000K
- Replacement button assemblies available in six styles to accommodate changes in device function or engravings
- Standard blank button assemblies available for engraving by a third-party
- Ambient light sensor for auto-dimming with separate day and night backlight modes
- Fully programmable via a Crestron control system

- Local button functionality for load control without programming
- Requires neutral wire connection
- Crestron Home® OS compatible
- Available in white, black, almond, white glass, and black glass
- Optionally mix standard and glass finishes

HZ2-KPEX Features

The [HZ2-KPEX](#) Horizon® 2 keypad provides infiNET EX® wireless network control of lighting, shading, audio, and other amenities. Its design matches the entire line of Horizon dimmers, switches, and keypads, making it a great addition to new or retrofit installations.

The HZ2-KPEX is available with default engraving on a five push button assembly (Style 1) or custom engraving on any style button assembly.

- Default engraving on a five pushbutton button assembly (Style 1) is provided with the HZ2-KPEX-A, HZ2-KPEX-W, HZ2-KPEX-B, HZ2-KPEX-GLASS-W, and HZ2-KPEX-GLASS-B. The default engraving includes a simple dot to provide feedback and indicate where the button can be pressed.



- Custom engraving on any style button assembly is provided with the HZ2-KPEX-A ENGRAVED, HZ2-KPEX-W ENGRAVED, HZ2-KPEX-B ENGRAVED, HZ2-KPEX-GLASS-W ENGRAVED, and HZ2-KPEX-GLASS-B ENGRAVED. The custom engraved button assembly is installed prior to shipment.



NOTE: Faceplates are not included. Refer to the [HZ2-FP-G series](#) faceplates for more information.

Key features include:

- Can act as a multiway controller for a connected dimmer or switch using a traveler wire in a traditional three- or four-way circuit ([HZ2-DIMEX](#), [HZ2-DIMUEX](#), and [HZ2-SWEX](#), all sold separately)
- Capable of being powered by either 120VAC line voltage or 60VDC low voltage (sold separately)
- Line based multiway control for reliability across all load types
- 1- to 4-gang U.S. wall box installation using Horizon® 2 multi-gang faceplates ([HZ2-FP-G](#) series, sold separately)
- Robust infiNET EX® wireless communication
- Preinstalled 5 single button assembly (Style 1) with default engraving or can be configured with six different button assemblies with custom engraving
- Multicolor RGB LEDs provide backlighting for engraved buttons
- White LED backlighting is available and can be dynamically set anywhere between 2000K and 8000K
- Replacement button assemblies available in six styles to accommodate changes in device function or engravings

- Standard blank button assemblies available for engraving by a third-party
- Ambient light sensor for auto-dimming with separate day and night backlight modes
- Fully programmable via a Crestron control system
- Local button functionality for load control without programming
- Requires neutral wire connection
- Crestron Home® OS compatible
- Available in white, black, almond, white glass, and black glass
- Optionally mix standard and glass finishes

HZ2-KPCN Features

The [HZ2-KPCN](#) Horizon® 2 keypad provides Cresnet® network control of lighting, shading, audio, and other amenities. Its design matches the entire line of Horizon dimmers, switches, and keypads, making it a great addition to new or retrofit installations.

The HZ2-KPCN is available with default engraving on a five push button assembly (Style 1) or custom engraving on any style button assembly.

- Default engraving on a five pushbutton button assembly (Style 1) is provided with the HZ2-KPCN-A, HZ2-KPCN-W, HZ2-KPCN-B, HZ2-KPCN-GLASS-W, and HZ2-KPCN-GLASS-B. The default engraving includes a simple dot to provide visual feedback and indicate where the button can be pressed.



- Custom engraving on any style button assembly is provided with the HZ2-KPCN-A ENGRAVED, HZ2-KPCN-W ENGRAVED, HZ2-KPCN-B ENGRAVED, HZ2-KPCN-GLASS-W ENGRAVED, and HZ2-KPCN-GLASS-B ENGRAVED. The custom engraved button assembly is installed prior to shipment.



Key features include:

- 1-gang EU/UK-style electrical box installation using the included metal backplate (-GLASS models require [HZ2-KPCN-WMKT-EU/UK-10](#), sold separately)
- Horizon® 2 faceplate (1-gang model [HZ2-FP-G](#) series) included with standard models (not included with -GLASS models)
- Multigang installation using Horizon® 2 multi-gang faceplates ([HZ2-FP-G](#) series, sold separately)
- Preinstalled 5 single button assembly (Style 1) with default engraving or can be configured with six different button assemblies with custom engraving
- Multicolor RGB LEDs provide backlighting for engraved buttons
- White LED backlighting is available and can be dynamically set anywhere between 2000K and 8000K
- Replacement button assemblies available in six styles to accommodate changes in device function or engravings
- Standard blank button assemblies available for engraving by a third-party
- Ambient light sensor for auto-dimming with separate day and night backlight modes
- Fully programmable via a Crestron control system
- Crestron Home® OS compatible
- Dual Cresnet® ports for easy daisy-chaining

- Two control input ports for external sensors
- Available in white, black, almond, white glass, and black glass
- Optionally mix standard and glass finishes

HZ2-AUX Features

The [HZ2-AUX](#) Horizon® 2 in-wall multiway remote controls Horizon 2 dimmers and switches. Its design matches the entire line of Horizon 2 dimmers, switches, and keypads, making it a great addition to new or retrofit installations.

NOTE: The HZ2-AUX only accepts the style 6 button assembly (large rocker) and does not have an LED backlight. For multiway control using a device that accepts any style button assembly and has LED backlighting, use an [HZ2-KPEX](#).

The HZ2-AUX is available with default engraving or custom engraving on a rocker button assembly (Style 6).

- Default engraving on a rocker button assembly (Style 6) is provided with the HZ2-AUX-A, HZ2-AUX-W, HZ2-AUX-B, HZ2-AUX-GLASS-W, and HZ2-AUX-GLASS-B. The default engraving includes a simple dot at the location where the button can be pressed.



- Custom engraving on a rocker button assembly (Style 6) provided with the HZ2-AUX-A ENGRAVED, HZ2-AUX-W ENGRAVED, HZ2-AUX-B ENGRAVED, HZ2-AUX-GLASS-W ENGRAVED, and HZ2-AUX-GLASS-B ENGRAVED. The custom engraved button assembly is installed prior to shipment.



NOTE: Faceplates are not included. Refer to the [HZ2-FP-G series](#) faceplates for more information.

Key features include:

- Provides control to the connected dimmer or switch using a traveler wire in a traditional three- or four-way circuit ([HZ2-DIMEX](#), [HZ2-DIMUEX](#), and [HZ2-SWEX](#), all sold separately)
- Line based multiway control for reliability across all load types
- 1- to 4-gang U.S. wall box installation using Horizon® 2 multi-gang faceplates ([HZ2-FP-G series](#), sold separately)
- Preinstalled large rocker button assembly (Style 6) with default engraving or can be configured with a large rocker button assembly (Style 6) with custom engraving
- Standard blank button assemblies available for engraving by a third-party
- Available in white, black, almond, white glass, and black glass

Multiway Dimming and Switching

Similar to traditional three- or four-way circuits, the HZ2-AUX lets you control the lights from multiple locations using the traveler wire. Up to four devices can be connected to a single dimmer or switch. The HZ2-AUX provides button backlights and six different engravable button assembly options while the HZ2-AUX provides no button backlight and only accommodates a single large rocker button assembly (Style 6). The multiway controller provides instant usability upon installation without the need for

programming.

NOTE: The HZ2-AUX cannot be used to control a load directly. It must be used in conjunction with a [HZ2-DIMEX](#), [HZ2-DIMUEX](#), and [HZ2-SWEX](#), (all sold separately).

HZ2A-KEY Features

The [HZ2A-KEY](#) Horizon® 2 keystone plate accepts 1, 2, or 4 keystone modules. The keystone plate is used in conjunction with keystone modules (sold separately) to fulfill the most complicated installation requirements.

Styled to match the Horizon® 2 devices, the keystone plate enables the connection of networking and AV equipment while maintaining an elegant look throughout the home while. Compatible with most third-party keystone modules (sold separately) to suit any application.

The keystone plates are available with one ([HZ2A-KEY1](#)), two ([HZ2A-KEY2](#)), and four ([HZ2A-KEY4](#)) openings for keystone modules and are available in White (-W), Almond (-A), and Black (-B).

HZ2A-KEY1-W

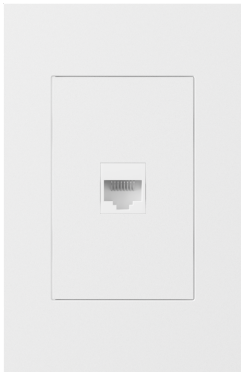

HZ2A-KEY2-B

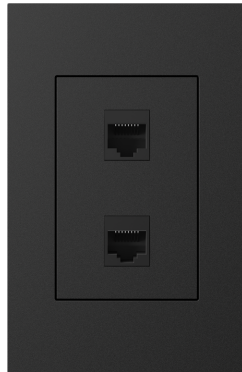

HZ2A-KEY4-A

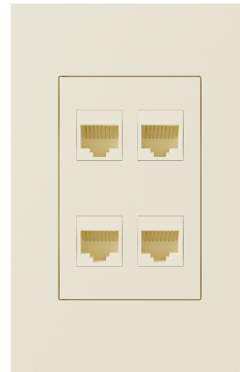

Key features include:

- Precision fit and finish for Horizon 2 devices
- 1, 2, or 4 keystone module positions
- Contiguous surface when multi-ganged
- Mount up to four Horizon® 2 devices with Horizon 2 multi-gang faceplates ([HZ2-FP-G](#) series, sold separately)
- Available in white, black, almond, white glass, and black glass

HZ2-BTNS Features

The [HZ2-BTNS](#) is a replacement button assembly for Horizon® 2 dimmers, switches, and keypads. Button assemblies are available in six styles to provide a variety of button configurations and each style is available in White (-W), Black (-B), Almond (-A), White Glass (-GLASS-W), and Black Glass (-GLASS-B).

Key features include:

- Replacement button assembly for Horizon® 2 dimmers, switches, and keypads
- Six button assembly styles are available to accommodate common button configurations
- Available blank or with custom engraving
- Engraved buttons can be backlit by a Horizon 2 dimmer, switch, or keypad
- Button assembly is field-replaceable without removing the device from the wall
- Available in white, black, almond, white glass, and black glass
- Optionally mix standard and glass finishes

HZ2-FP-G Features

Horizon® 2 faceplates ([HZ2-FP-G](#) series) are essential installation components of every Horizon 2 installation to provide a finished appearance with customizable design elements. Each faceplate features side panels that match the keypad's textured button faces to provide a clean, contiguous surface from edge to edge.

Key features include:

- Precision fit and finish for Horizon 2 devices
- Available in 1, 2, 3, and 4 gang sizes
- Decorator-style options available
- Available in white, black, almond, white glass, and black glass

Install up to four Horizon® 2 devices side-by-side in a US multigang electrical box with a compatible [HZ2-FP-G](#) series faceplate. When multiple devices are installed in a 2-, 3-, or 4-gang faceplate, the buttons on the devices are aligned to form one continuous control surface.

Horizon 2 Faceplates Supporting Decorator-Style Devices

Decorator-style faceplates (FP-G-D series) accommodate a wide variety of Decorator-style third party devices alongside Horizon 2 devices. They are offered in white, black, and almond in a variety of configurations. Nonsymmetrical faceplates can be reversed to support the decorator-style device on either side of the Horizon 2 device(s).

HZ2-FP-G1 shown in White

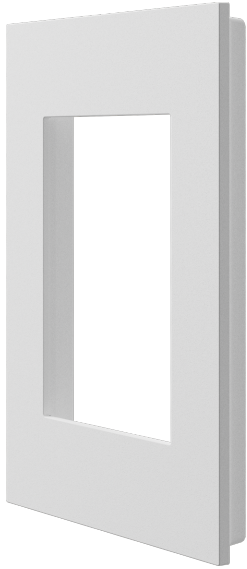

HZ2-FP-G2 shown in White

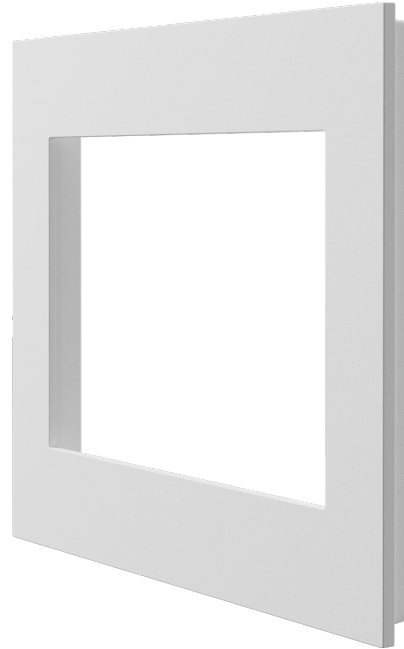

HZ2-FP-G3 shown in White

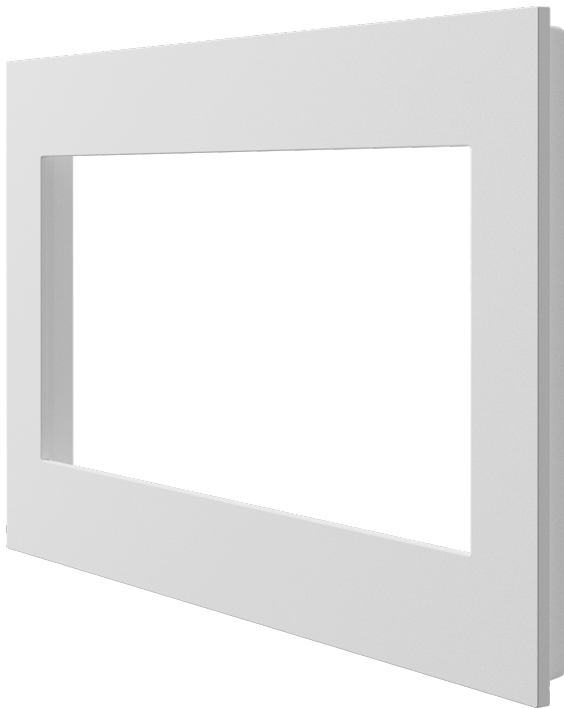

HZ2-FP-G4 shown in White

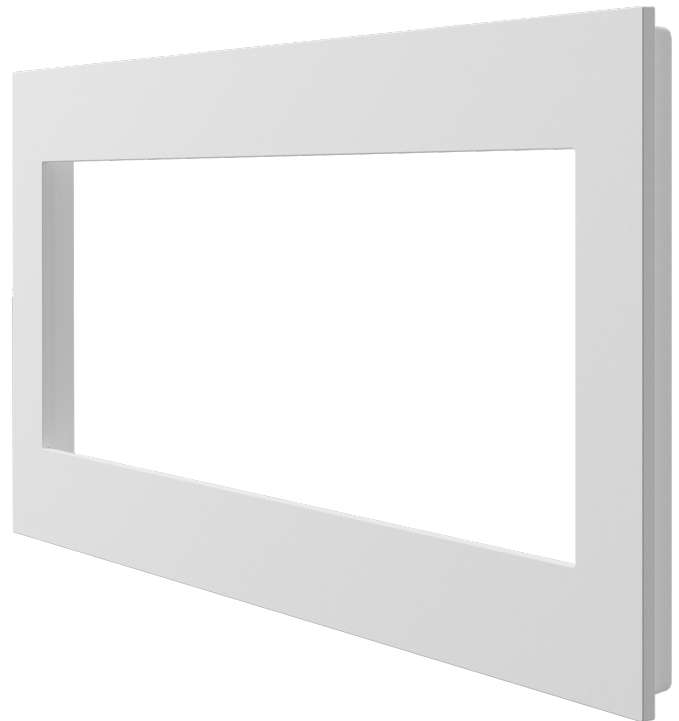

HZ2-FP-G1-D1 shown in White

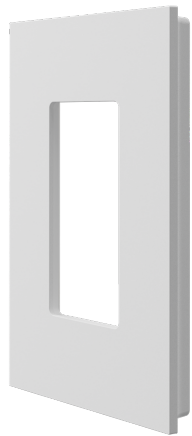

HZ2-FP-G2-D1 shown in White

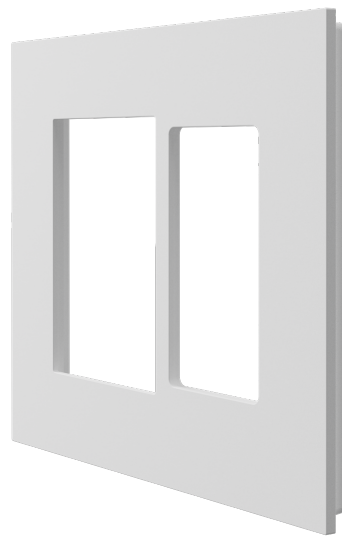

HZ2-FP-G2-D2 shown in White



HZ2-FP-G3-D1 shown in White

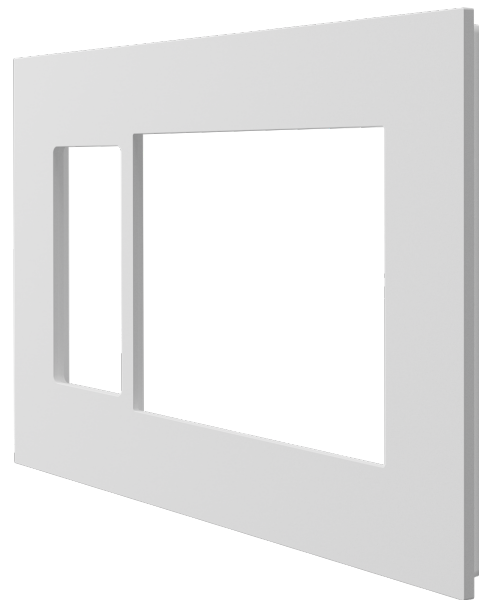

HZ2-FP-G4-D1 shown in White

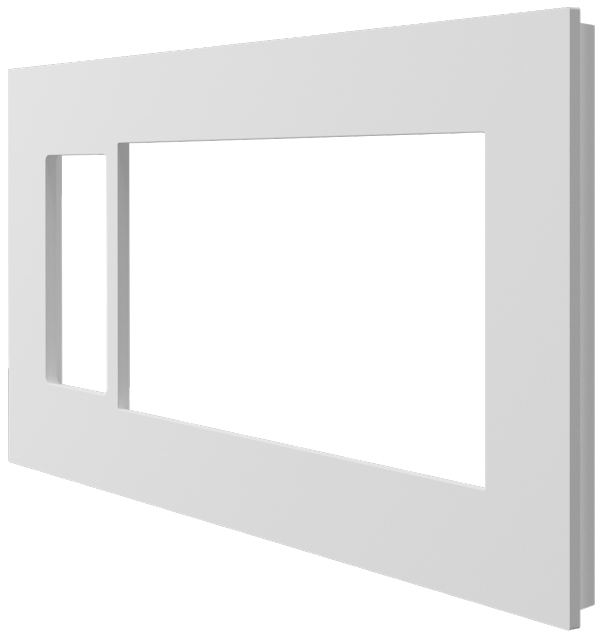

Specifications

This section provides the following information:

- [HZ2-DIMEX Specifications](#)
- [HZ2-DIMLVEX Specifications](#)
- [HZ2-DIMUEX Specifications](#)
- [HZ2-SWEX Specifications](#)
- [HZ2-KPEX Specifications](#)
- [HZ2-KPCN Specifications](#)
- [HZ2-AUX Specifications](#)
- [HZ2A-KEY Specifications](#)
- [HZ2-FP-G Specifications](#)

HZ2-DIMEX Specifications

Product specifications for the HZ2-DIMEX.

Product Specifications

Load Control

Load Type	Incandescent, Magnetic Low Voltage, Tungsten-Halogen
Channels	1
Load Rating	750 W/VA maximum; No minimum load
Preset Fade Time	1 second (default), when operated without a control system; Fade time is adjustable when controlled by a control system

Power Requirements

120VAC, 50/60 Hz;
Requires neutral wire connection

Controls

Push button	(9) Push buttons, located under the button assembly; Push buttons are actuated by the button assembly that is installed
Airgap	(1) Switch at the bottom of the device; Controls power to the device and connected loads
Button Assembly	(1) Button assembly included; Default engraving: Includes default engraving on a Style 6 button assembly; Custom engraving (ENGRAVED models): Includes custom engraving on any style button assembly; Compatible with Style 1–6 button assemblies

NOTE: The center of a rocker-style button cannot be used to actuate a push button. Rocker buttons are included on the HZ2-BTNS-2, HZ2-BTNS-3, HZ2-BTNS-4, HZ2-BTNS-5, and HZ2-BTNS-6 button assemblies.

Setup	(1) Push button; Front of the faceplate must be removed to access the push button; Can be used to set the local LED backlight color theme or calibrate the ambient light sensor
--------------	---

LED Indicator and Light Sensor

LED Feedback	(5) RGB LED backlights; Supports one local color theme for all LEDs; Supports one alternate color theme for each backlit position
---------------------	---

Light Sensor	(1) Photosensor with adjustable sensitivity; Detects the ambient room light level to activate day or night mode and autodimming the backlight
---------------------	--

NOTE: Light sensor performance may be affected by obstructions placed below the keypad.

Wireless

RF Transceiver	inFINET EX® 2-way RF, 2.4 GHz ISM Channels 11-26 (2400 to 2483.5 MHz), default channel 15; IEEE 802.15.4 compliant
Range (typical)	150 ft (46 m) indoor, 250 ft (76 m) outdoor to nearest mesh network device; Subject to site-specific conditions and individual device capabilities
Gateway	Requires a Crestron Wireless Gateway (sold separately)

Connections

Load	(1) Screw clamp terminal, consists of (2) wire inserts and (1) red screw head; Load output; Accepts (1) 14-12 AWG wire per insert, do not insert wires behind screw head
Line	(1) Screw clamp terminal, consists of (2) wire inserts and (1) black screw head; Line power input; Accepts (1) 14-12 AWG wire per insert, do not insert wires behind screw head
Neutral	(1) Screw clamp terminal, consists of (2) wire inserts and (1) silver screw head; Neutral input; Accepts (1) 14-12 AWG wire per insert, do not insert wires behind screw head
Remote	(1) Screw clamp terminal, consists of (2) wire inserts and (1) blue screw head; Remote input from HZ2-AUX or HZ2-KPEX ; Accepts (1) 14-12 AWG wire per insert, do not insert wires behind screw head
Ground	(1) 12 AWG flying lead, Class 1, green with yellow stripe; Ground; Wire nut included

Environmental

Temperature	32° to 86°F (0° to 30°C)
Humidity	10% to 90% RH (noncondensing)

Construction

Mounting	Mounts in a 1- to 4-gang U.S. electrical box (not included); 3.5 in. (26 mm) electrical box depth recommended; Derating required in multigang applications
-----------------	--

Faceplate

Requires a Horizon® 2 faceplate ([HZ2-FP-G](#), sold separately, metal backplate included with faceplate);
Multigang installations require a 2-, 3-, or 4-gang Horizon® 2 faceplate with metal backplate ([HZ2-FP-G](#), sold separately);
The metal backplate is required for all installations where the electrical box is flush with or recessed from the wall surface;
The metal backplate is not recommended for electrical boxes that protrude beyond the wall surface

Dimensions

Height	4.13 in. (105 mm), air-gap switch extends 0.26 in. (7 mm) from bottom of keypad
Width	1.80 in. (46 mm)
Depth (Standard)	1.75 in. (45 mm) overall, extends 0.44 in. (12 mm) from wall surface when installed
Depth (Glass)	1.83 in. (47 mm) overall, extends 0.46 in. (12 mm) from wall surface when installed

Weight

7.4 oz (208 g)

Compliance

FCC, UL, IC

Regulatory Model: M201849003

1. Any infiNET EX device that provides expander functionality will effectively extend the range of the wireless network beyond the initial range of the gateway. Battery-powered infiNET EX devices do not provide expander functionality. A dedicated infiNET EX Wireless Expander, model CLW-EXPEX (sold separately), is also available.

Dimension Drawings

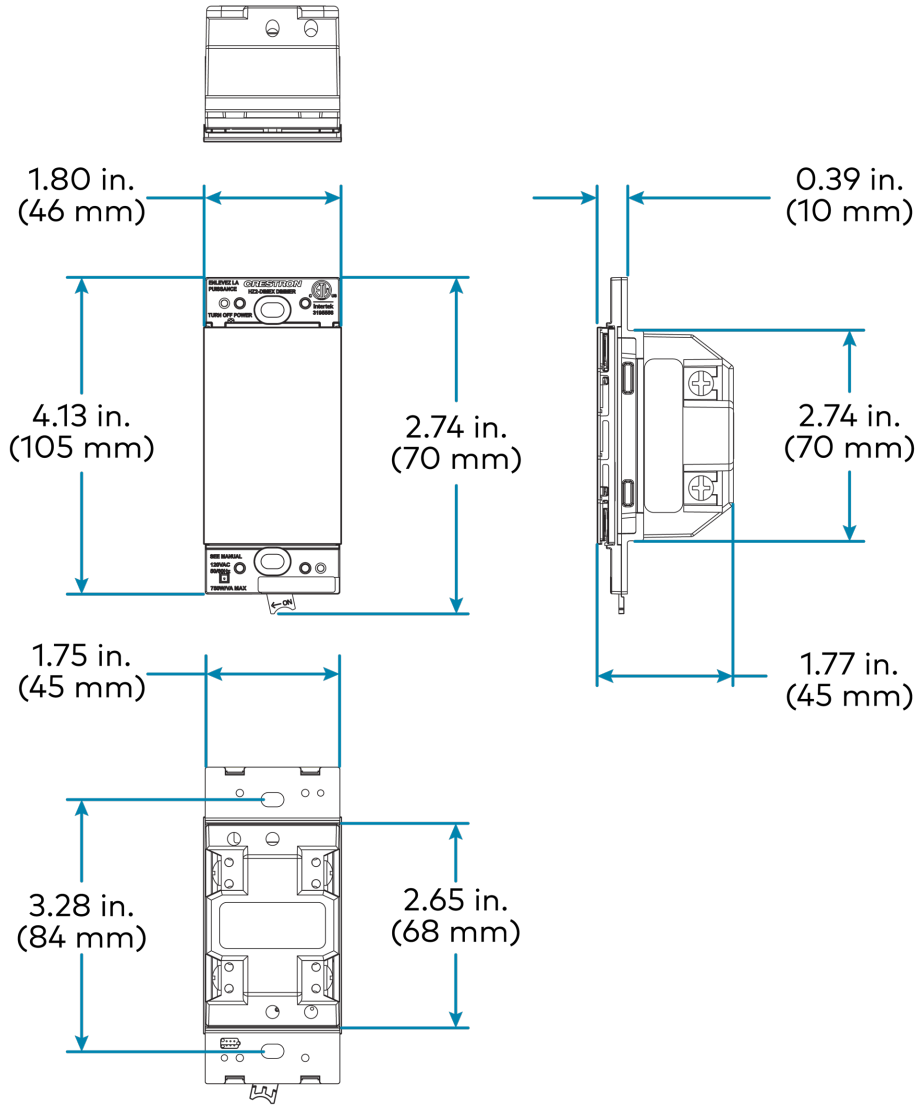

HZ2-DIMLVEX Specifications

Product specifications for the HZ2-DIMLVEX.

Product Specifications

Load Control

Load Type	0-10VDC Ballasts, LED Drivers
Load Rating	10A maximum; No minimum load
Dim Control Output	0-10VDC 60 mA sink/source
Preset Fade Time	1 second (default), when operated without a control system; Fade time is adjustable when controlled by a control system

Power Requirements

120VAC, 50/60 Hz;
Requires neutral wire connection

Controls

Push button	(9) Push buttons, located under the button assembly; Push buttons are actuated by the button assembly that is installed
Button Assembly	(1) Button assembly included; Default engraving: Includes default engraving on a Style 6 button assembly; Custom engraving (ENGRAVED models): Includes custom engraving on any style button assembly; Compatible with Style 1–6 button assemblies
	NOTE: The center of a rocker-style button cannot be used to actuate a push button. Rocker buttons are included on the HZ2-BTNS-2, HZ2-BTNS-3, HZ2-BTNS-4, HZ2-BTNS-5, and HZ2-BTNS-6 button assemblies.
Setup	(1) Push button; Front of the faceplate must be removed to access the push button; Can be used to set the local LED backlight color theme or calibrate the ambient light sensor

LED Indicator and Light Sensor

LED Feedback	(5) RGB LED backlights; Supports one local color theme for all LEDs; Supports one alternate color theme for each backlit position
Light Sensor	(1) Photosensor with adjustable sensitivity; Detects the ambient room light level to activate day or night mode and autodimming the backlight

NOTE: Light sensor performance may be affected by obstructions placed below the keypad.

Wireless

RF Transceiver	inFiNET EX® 2-way RF, 2.4 GHz ISM Channels 11-26 (2400 to 2483.5 MHz), default channel 15; IEEE 802.15.4 compliant
Range (typical)	150 ft (46 m) indoor, 250 ft (76 m) outdoor to nearest mesh network device; Subject to site-specific conditions and individual device capabilities
Gateway	Requires a Crestron Wireless Gateway (sold separately)

Connections

HOT	(1) 12 AWG flying lead; Black, line power input (wire nut included)
NEU	(1) 12 AWG flying lead; White, neutral (wire nut included)
LOAD	(1) 12 AWG flying lead; Red, switched power output to load (wire nut included)
GND	(1) 12 AWG flying lead; Green with yellow stripe, ground (wire nut included)
DIM +	(1) 12 AWG flying lead; Purple, 0–10V dimming control output, positive (wire nut included)
DIM -	(1) 12 AWG flying lead; Pink, 0–10V dimming control output, negative (wire nut included)

NOTE: The older version of this product had gray wire for DIM -.

Environmental

Temperature	32° to 86°F (0° to 30°C)
Humidity	10% to 90% RH (noncondensing)

Construction

Mounting	Mounts in a 1- to 4-gang U.S. electrical box (not included); 3.5 in. (26 mm) electrical box depth recommended; Derating required in multigang applications
Faceplate	Requires a Horizon® 2 faceplate (HZ2-FP-G , sold separately, metal backplate included with faceplate); Multigang installations require a 2-, 3-, or 4-gang Horizon® 2 faceplate with metal backplate (HZ2-FP-G , sold separately); The metal backplate is required for all installations where the electrical box is flush with or recessed from the wall surface; The metal backplate is not recommended for electrical boxes that protrude beyond the wall surface

Dimensions

Height	4.13 in. (105 mm)
---------------	-------------------

Width	1.80 in. (46 mm)
Depth (Standard)	1.75 in. (45 mm) overall, extends 0.44 in. (12 mm) from wall surface when installed
Depth (Glass)	1.89 in. (48 mm) overall, extends 0.46 in. (12 mm) from wall surface when installed

Weight

7.4 oz (208 g)

Compliance

FCC, UL, IC

Regulatory Model: M201849005

1. Any infiNET EX device that provides expander functionality will effectively extend the range of the wireless network beyond the initial range of the gateway. Battery-powered infiNET EX devices do not provide expander functionality. A dedicated infiNET EX Wireless Expander, model CLW-EXPEX (sold separately), is also available.

Dimension Drawings

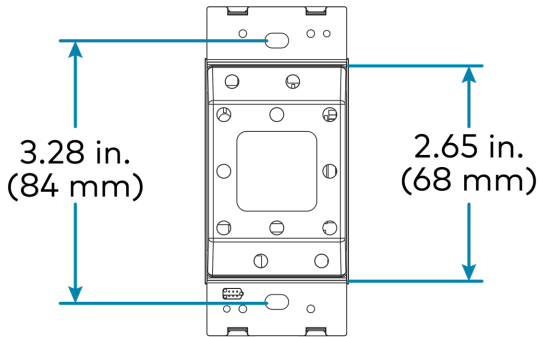
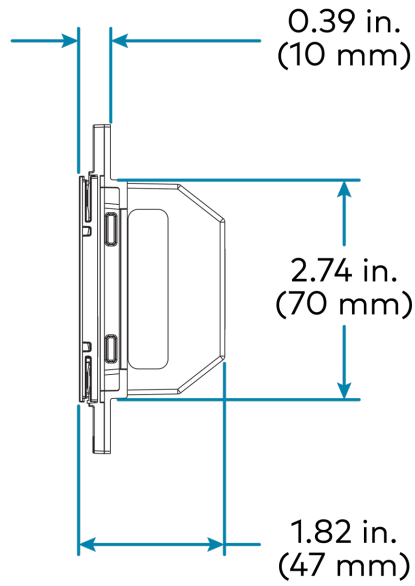
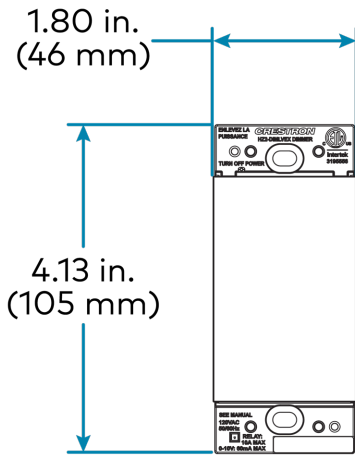
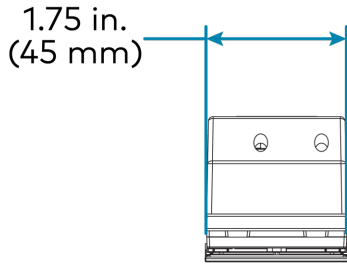

HZ2-DIMUEX Specifications

Product specifications for the HZ2-DIMUEX.

Product Specifications

Load Control

Load Type	LED, Incandescent, Magnetic Low Voltage, Electronic Low Voltage
Load Rating	600 W/VA maximum; No minimum load
Preset Fade Time	1 second (default), when operated without a control system; Fade time is adjustable when controlled by a control system

Power Requirements

120VAC, 50/60 Hz;
Requires neutral wire connection

Controls

Push button	(9) Push buttons, located under the button assembly; Push buttons are actuated by the button assembly that is installed
Airgap	(1) Switch at the bottom of the device; Controls power to the device and connected loads
Button Assembly	(1) Button assembly included; Default engraving: Includes default engraving on a Style 6 button assembly; Custom engraving (ENGRAVED models): Includes custom engraving on any style button assembly; Compatible with Style 1–6 button assemblies

NOTE: The center of a rocker-style button cannot be used to actuate a push button. Rocker buttons are included on the HZ2-BTNS-2, HZ2-BTNS-3, HZ2-BTNS-4, HZ2-BTNS-5, and HZ2-BTNS-6 button assemblies.

Engraving Options	The device is available with the following engraving options: <ul style="list-style-type: none">• Engraved: Devices ordered with the ENGRAVED option include (1) Style 1-6 button assembly with custom engraving. The engraved button assembly is installed onto the device prior to shipment.• Default Engraved : Default engraving consists of a simple dot that provides feedback and indicates where the button can be pressed. The default button assembly with default engraving is installed onto the device prior to shipment.
Setup	(1) Push button; Front of the faceplate must be removed to access the push button; Can be used to set the local LED backlight color theme or calibrate the ambient light sensor

LED Indicator and Light Sensor

LED Feedback	(5) RGB LED backlights; Supports one local color theme for all LEDs; Supports one alternate color theme for each backlit position
Light Sensor	(1) Photosensor with adjustable sensitivity; Detects the ambient room light level to activate day or night mode and autodimming the backlight

NOTE: Light sensor performance may be affected by obstructions placed below the keypad.

Wireless

RF Transceiver	infiNET EX® 2-way RF, 2.4 GHz ISM Channels 11-26 (2400 to 2483.5 MHz), default channel 15; IEEE 802.15.4 compliant
Range (typical)	150 ft (46 m) indoor, 250 ft (76 m) outdoor to nearest mesh network device; Subject to site-specific conditions and individual device capabilities
Gateway	Requires a Crestron Wireless Gateway (sold separately)

Connections

Load	(1) Screw clamp terminal, consists of (2) wire inserts and (1) red screw head; Load output; Accepts (1) 14-12 AWG wire per insert, do not insert wires behind screw head
Line	(1) Screw clamp terminal, consists of (2) wire inserts and (1) black screw head; Line power input; Accepts (1) 14-12 AWG wire per insert, do not insert wires behind screw head
Neutral	(1) Screw clamp terminal, consists of (2) wire inserts and (1) silver screw head; Neutral input; Accepts (1) 14-12 AWG wire per insert, do not insert wires behind screw head
Remote	(1) Screw clamp terminal, consists of (2) wire inserts and (1) blue screw head; Remote input from HZ2-AUX or HZ2-KPEX ; Accepts (1) 14-12 AWG wire per insert, do not insert wires behind screw head
Ground	(1) 12 AWG flying lead, Class 1, green with yellow stripe; Ground; Wire nut included

Environmental

Temperature	32° to 86°F (0° to 30°C)
Humidity	10% to 90% RH (noncondensing)

Construction

Mounting	Mounts in a 1- to 4-gang U.S. electrical box (not included); 3.5 in. (26 mm) electrical box depth recommended; Derating required in multigang applications
-----------------	--

Faceplate

Requires a Horizon® 2 faceplate ([HZ2-FP-G](#), sold separately, metal backplate included with faceplate);
Multigang installations require a 2-, 3-, or 4-gang Horizon® 2 faceplate with metal backplate ([HZ2-FP-G](#), sold separately);
The metal backplate is required for all installations where the electrical box is flush with or recessed from the wall surface;
The metal backplate is not recommended for electrical boxes that protrude beyond the wall surface

Dimensions

Height	4.13 in. (105 mm), air-gap switch extends 0.26 in. (7 mm) from bottom of keypad
Width	1.80 in. (46 mm)
Depth (Standard)	1.75 in. (45 mm) overall, extends 0.44 in. (12 mm) from wall surface when installed
Depth (Glass)	1.83 in. (47 mm) overall, extends 0.46 in. (12 mm) from wall surface when installed

Weight

7.4 oz (208 g)

Compliance

FCC, UL, IC

Regulatory Model: M201849004

1. Any infiNET EX device that provides expander functionality will effectively extend the range of the wireless network beyond the initial range of the gateway. Battery-powered infiNET EX devices do not provide expander functionality. A dedicated infiNET EX Wireless Expander, model CLW-EXPEX (sold separately), is also available.

Dimension Drawings

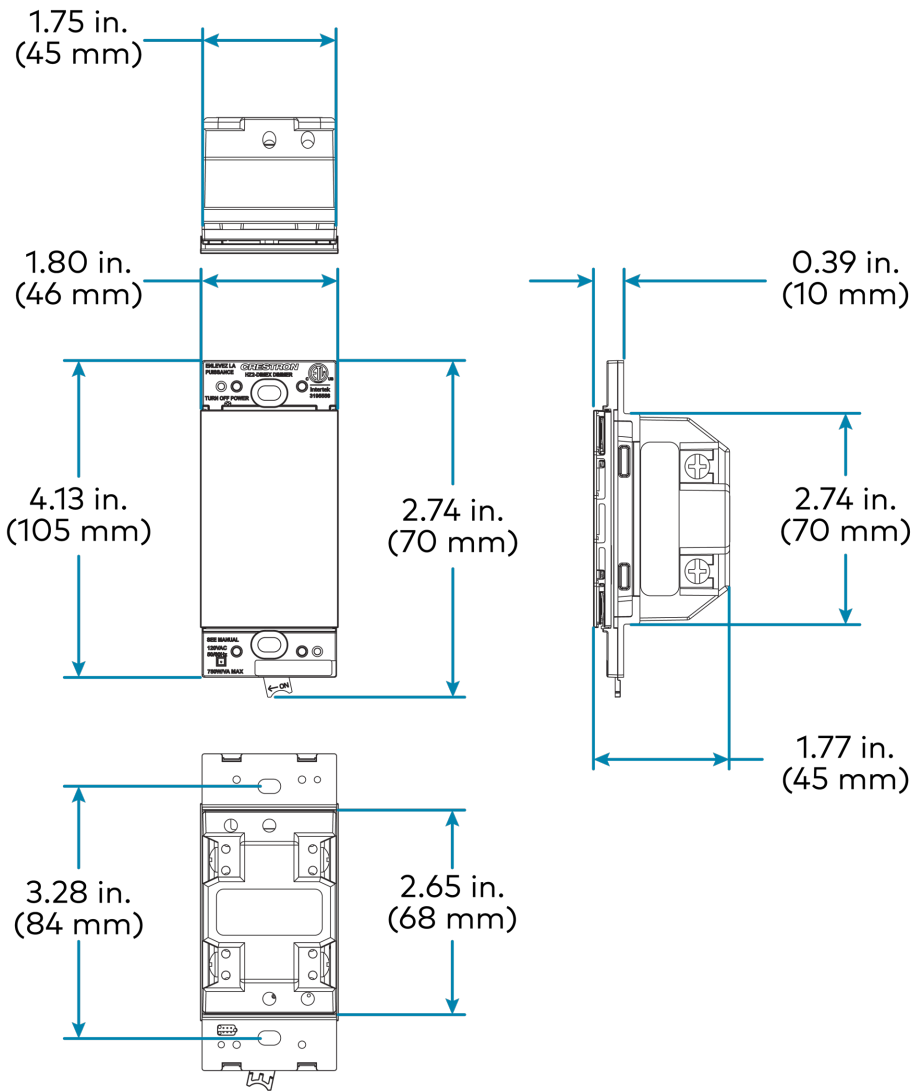

HZ2-SWEX Specifications

Product specifications for the HZ2-SWEX.

Product Specifications

Load Control

Load Type	Incandescent, Magnetic Low Voltage, Tungsten-Halogen, Electronic Ballasts, 1/2 HP Motors
Load Rating	10A maximum; No minimum load

Power Requirements

120VAC, 50/60 Hz;
Requires neutral wire connection

Controls

Push button	(9) Push buttons, located under the button assembly; Push buttons are actuated by the button assembly that is installed
Button Assembly	(1) Button assembly included; Default engraving: Includes default engraving on a Style 6 button assembly; Custom engraving (ENGRAVED models): Includes custom engraving on any style button assembly; Compatible with Style 1–6 button assemblies

NOTE: The center of a rocker-style button cannot be used to actuate a push button. Rocker buttons are included on the HZ2-BTNS-2, HZ2-BTNS-3, HZ2-BTNS-4, HZ2-BTNS-5, and HZ2-BTNS-6 button assemblies.

Setup	(1) Push button; Front of the faceplate must be removed to access the push button; Can be used to set the local LED backlight color theme or calibrate the ambient light sensor
--------------	---

LED Indicator and Light Sensor

LED Feedback	(5) RGB LED backlights; Supports one local color theme for all LEDs; Supports one alternate color theme for each backlit position
Light Sensor	(1) Photosensor with adjustable sensitivity; Detects the ambient room light level to activate day or night mode and autodimming the backlight

NOTE: Light sensor performance may be affected by obstructions placed below the keypad.

Wireless

RF Transceiver	infiNET EX® 2-way RF, 2.4 GHz ISM Channels 11-26 (2400 to 2483.5 MHz), default channel 15; IEEE 802.15.4 compliant
Range (typical)	150 ft (46 m) indoor, 250 ft (76 m) outdoor to nearest mesh network device; Subject to site-specific conditions and individual device capabilities
Gateway	Requires a Crestron Wireless Gateway (sold separately)

Connections

Load	(1) Screw clamp terminal, consists of (2) wire inserts and (1) red screw head; Load output; Accepts (1) 14-12 AWG wire per insert, do not insert wires behind screw head
Line	(1) Screw clamp terminal, consists of (2) wire inserts and (1) black screw head; Line power input; Accepts (1) 14-12 AWG wire per insert, do not insert wires behind screw head
Neutral	(1) Screw clamp terminal, consists of (2) wire inserts and (1) silver screw head; Neutral input; Accepts (1) 14-12 AWG wire per insert, do not insert wires behind screw head
Remote	(1) Screw clamp terminal, consists of (2) wire inserts and (1) blue screw head; Remote input from HZ2-AUX or HZ2-KPEX ; Accepts (1) 14-12 AWG wire per insert, do not insert wires behind screw head
Ground	(1) 12 AWG flying lead, Class 1, green with yellow stripe; Ground; Wire nut included

Environmental

Temperature	32° to 86°F (0° to 30°C)
Humidity	10% to 90% RH (noncondensing)

Construction

Mounting	Mounts in a 1- to 4-gang U.S. electrical box (not included); 3.5 in. (26 mm) electrical box depth recommended; Derating required in multigang applications
Faceplate	Requires a Horizon® 2 faceplate (HZ2-FP-G , sold separately, metal backplate included with faceplate); Multigang installations require a 2-, 3-, or 4-gang Horizon® 2 faceplate with metal backplate (HZ2-FP-G , sold separately); The metal backplate is required for all installations where the electrical box is flush with or recessed from the wall surface; The metal backplate is not recommended for electrical boxes that protrude beyond the wall surface

Dimensions

Height	4.13 in. (105 mm)
Width	1.80 in. (46 mm)

Depth (Standard)	1.75 in. (45 mm) overall, extends 0.44 in. (12 mm) from wall surface when installed
Depth (Glass)	1.83 in. (47 mm) overall, extends 0.46 in. (12 mm) from wall surface when installed

Weight

7.4 oz (208 g)

Compliance

FCC, UL, IC

Regulatory Model: M201849002

- Any infiNET EX device that provides expander functionality will effectively extend the range of the wireless network beyond the initial range of the gateway. Battery-powered infiNET EX devices do not provide expander functionality. A dedicated infiNET EX Wireless Expander, model CLW-EXPEX (sold separately), is also available.

Dimension Drawings

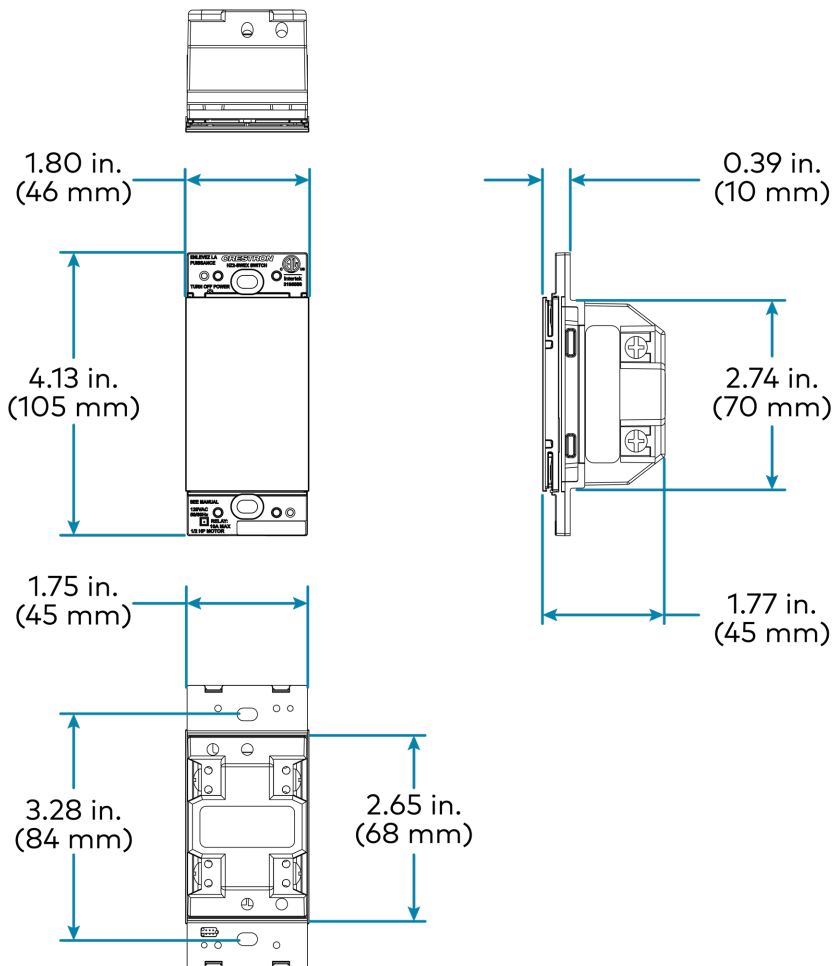

HZ2-KPEX Specifications

Product specifications for the HZ2-KPEX.

Product Specifications

Power Requirements

Line Power	120VAC, 50/60 Hz; Requires neutral wire connection
DC Power	60VDC, 30 mA ; Requires a SolaHD® SDP™ 1-48-100T power supply (sold separately)

Controls

Push button	(9) Push buttons, located under the button assembly; Push buttons are actuated by the button assembly that is installed
Airgap	(1) Switch at the bottom of the device; Controls power to the device and connected loads
Button Assembly	(1) Button assembly included; Default engraving: Includes default engraving on a Style 1 button assembly; Custom engraving (ENGRAVED models): Includes custom engraving on any style button assembly; Compatible with Style 1–6 button assemblies

NOTE: The center of a rocker-style button cannot be used to actuate a push button. Rocker buttons are included on the HZ2-BTNS-2, HZ2-BTNS-3, HZ2-BTNS-4, HZ2-BTNS-5, and HZ2-BTNS-6 button assemblies.

Setup	(1) Push button; Front of the faceplate must be removed to access the push button; Can be used to set the local LED backlight color theme or calibrate the ambient light sensor
-------	---

NOTE: The HZ2-KPEX cannot be used to control a load directly. It must be used in conjunction with a HZ2-DIMEX, HZ2-DIMUEX, or HZ2-SWEX.

LED Indicator and Light Sensor

LED Feedback	(5) RGB LED backlights; Supports one local color theme for all LEDs; Supports one alternate color theme for each backlit position
Light Sensor	(1) Photosensor with adjustable sensitivity; Detects the ambient room light level to activate day or night mode and autodimming the backlight

NOTE: Light sensor performance may be affected by obstructions placed below the keypad.

Wireless

RF Transceiver	infiNET EX® 2-way RF, 2.4 GHz ISM Channels 11-26 (2400 to 2483.5 MHz), default channel 15; IEEE 802.15.4 compliant
Range (typical)	150 ft (46 m) indoor, 250 ft (76 m) outdoor to nearest mesh network device; Subject to site-specific conditions and individual device capabilities
Gateway	Requires a Crestron Wireless Gateway (sold separately)

Connections

Line	(1) Screw clamp terminal, consists of (2) wire inserts and (1) black screw head; Line power input; Accepts (1) 14-12 AWG wire per insert, do not insert wires behind screw head
Neutral	(1) Screw clamp terminal, consists of (2) wire inserts and (1) silver screw head; Neutral input; Accepts (1) 14-12 AWG wire per insert, do not insert wires behind screw head
Remote	(1) Screw clamp terminal, consists of (2) wire inserts and (1) blue screw head; Remote input from HZ2-AUX or HZ2-KPEX ; Accepts (1) 14-12 AWG wire per insert, do not insert wires behind screw head
Ground	(1) 12 AWG flying lead, Class 1, green with yellow stripe; Ground; Wire nut included

Environmental

Temperature	32° to 86°F (0° to 30°C)
Humidity	10% to 90% RH (noncondensing)

Construction

Mounting	Mounts in a 1- to 4-gang U.S. electrical box (not included); 3.5 in. (26 mm) electrical box depth recommended; Derating required in multigang applications
Faceplate	Requires a Horizon® 2 faceplate (HZ2-FP-G , sold separately, metal backplate included with faceplate); Multigang installations require a 2-, 3-, or 4-gang Horizon® 2 faceplate with metal backplate (HZ2-FP-G , sold separately); The metal backplate is required for all installations where the electrical box is flush with or recessed from the wall surface; The metal backplate is not recommended for electrical boxes that protrude beyond the wall surface

Dimensions

Height	4.13 in. (105 mm), air-gap switch extends 0.26 in. (7 mm) from bottom of keypad
Width	1.80 in. (46 mm)
Depth (Standard)	1.75 in. (45 mm) overall, extends 0.44 in. (12 mm) from wall surface when installed
Depth (Glass)	1.83 in. (47 mm) overall, extends 0.46 in. (12 mm) from wall surface when installed

Weight

7.4 oz (208 g)

Compliance

FCC, UL, IC

Regulatory Model: M201849001

1. Any inFiNET EX device that provides expander functionality will effectively extend the range of the wireless network beyond the initial range of the gateway. Battery-powered inFiNET EX devices do not provide expander functionality. A dedicated inFiNET EX Wireless Expander, model CLW-EXPEX (sold separately), is also available.

Dimension Drawings

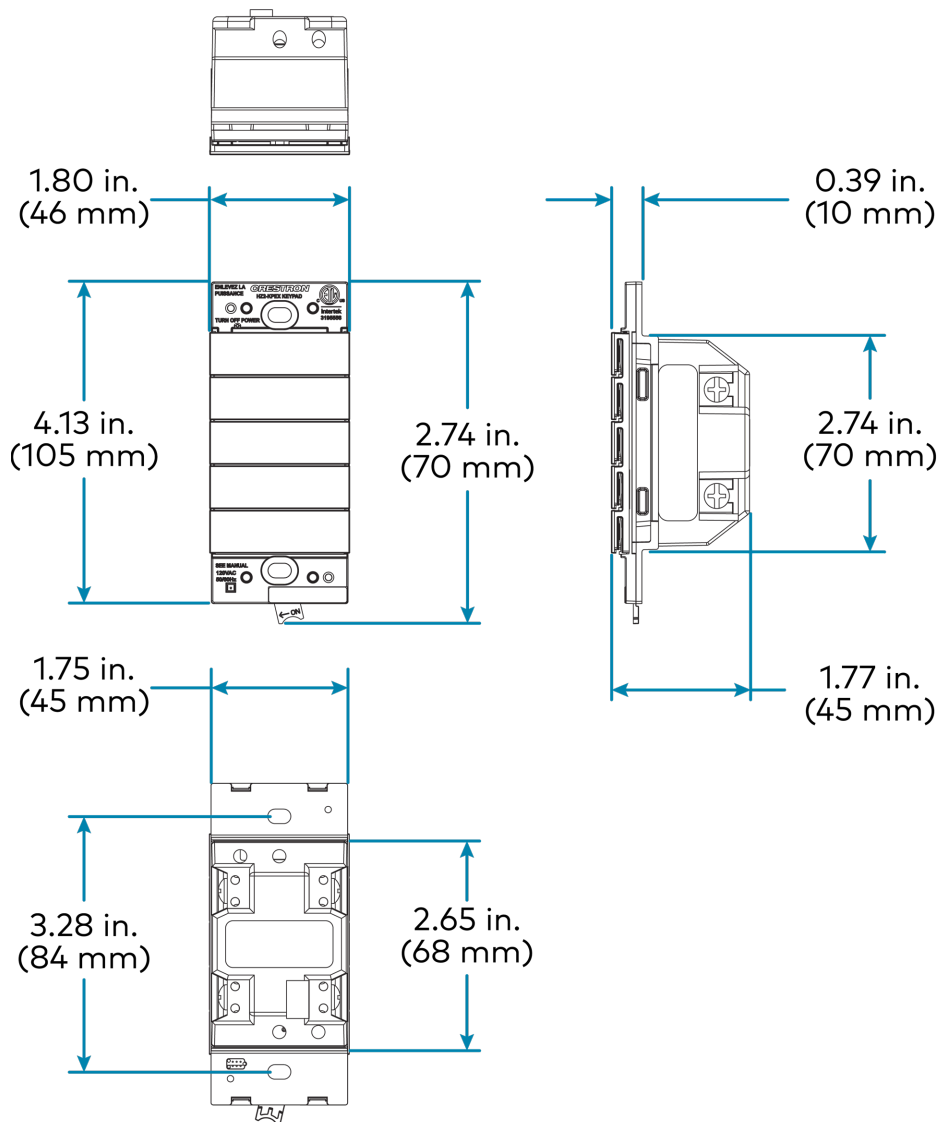

HZ2-KPCN Specifications

Product specifications for the HZ2-KPCN.

Product Specifications

Power Requirements

Cresnet Power Usage 2 W (83 mA @ 24VDC)

Controls

Push button	(9) Push buttons, located under the button assembly; Push buttons are actuated by the button assembly that is installed
Button Assembly	(1) Button assembly included; Default engraving: Includes default engraving on a Style 1 button assembly; Custom engraving (ENGRAVED models): Includes custom engraving on any style button assembly; Compatible with Style 1–6 button assemblies
Setup	(1) Push button; Front of the faceplate must be removed to access the push button; Can be used to set the local LED backlight color theme or calibrate the ambient light sensor

LED Indicator and Light Sensor

LED Feedback	(5) RGB LED backlights; Supports one local color theme for all LEDs; Supports one alternate color theme for each backlit position
Light Sensor	(1) Photosensor with adjustable sensitivity; Detects the ambient room light level to activate day or night mode and autodimming the backlight

NOTE: Light sensor performance may be affected by obstructions placed below the keypad.

Communications

Cresnet Cresnet client mode

Connections

INPUT (1 2 G)	(1) 3-pin 3.5 mm detachable terminal block; (2) digital/analog input ports, (1) ground; Digital Input: Rated for 0–24VDC, input impedance 200k Ω , logic threshold 1.24VDC; Analog Input: Rated for 0–10VDC, protected to 24VDC maximum, input impedance 200k Ω ; Programmable 3V, 2k Ω pull-up resistor per input
NET (24 Y Z G)	(2) 4-pin 3.5 mm detachable terminal blocks, paralleled; Cresnet secondary port with hardware parallel pass-through

Environmental

Temperature	32° to 86°F (0° to 30°C)
Humidity	10% to 90% RH (noncondensing)

Construction

Mounting	Mounts in a 1- to 4-gang U.S. or 1-gang EU style electrical box (not included); Note: -GLASS models require HZ2-KPCN-WMKT-EU/UK-10 (sold separately) for mounting in EU style electrical boxes; 3.5 in. (26 mm) electrical box depth recommended
Faceplate	Horizon® 2 faceplate required for installation; 1-gang faceplate (HZ-FP-G) with one-piece metal backplate is included with standard models Multigang installations require a 2-, 3-, or 4-gang Horizon® 2 faceplate with metal backplate (HZ-FP-G , sold separately); The metal backplate is required for all installations where the electrical box is flush with or recessed from the wall surface and during installation into a 1-gang EU style electrical box; The metal backplate is not recommended for electrical boxes that protrude beyond the wall surface

Dimensions

Height	4.13 in. (105 mm) without faceplate
Width	1.80 in. (46 mm)
Depth (Standard)	0.64 in. (17 mm) overall, projects 0.44 in. (12 mm) from wall surface when installed
Depth (Glass)	0.71 in. (18 mm) overall, projects 0.46 in. (12 mm) from wall surface when installed

NOTE: Dimensions shown are without the detachable connectors.

Weight

7.4 oz (208 g)

Compliance

IC, FCC Part 15 Class B digital device

Regulatory Model: M201849007

Dimension Drawings

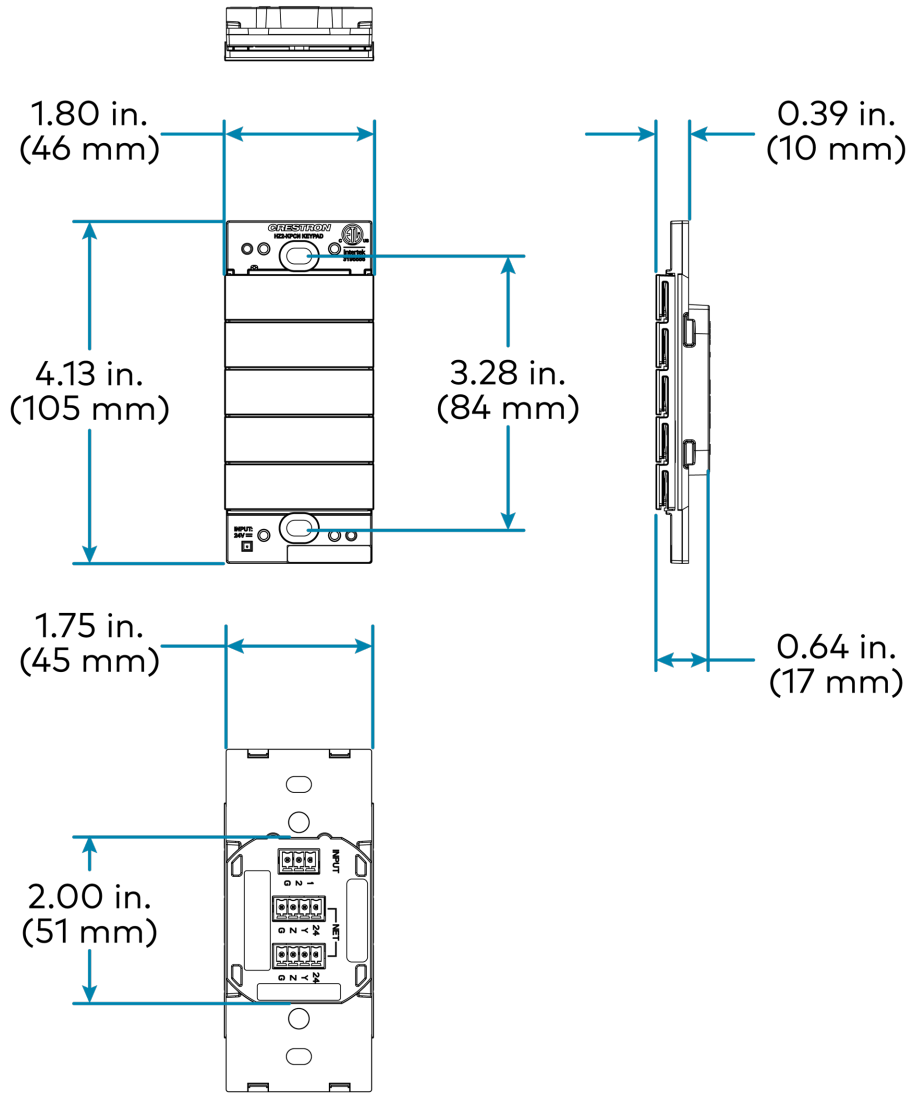

HZ2-AUX Specifications

Product specifications for the HZ2-AUX.

Product Specifications

Power Requirements

120VAC, 50/60 Hz

Controls

Push button	(2) Push buttons, located under the button assembly; Push buttons are actuated by the button assembly that is installed
Button Assembly	(1) Button assembly included; Default engraving: Includes default engraving on a Style 6 button assembly; Custom engraving (ENGRAVED models): Includes custom engraving on a Style 6 button assembly; Compatible with Style 6 button assemblies

NOTE: The center of a rocker-style button cannot be used to actuate a push button. Rocker buttons are included on the HZ2-BTNS-2, HZ2-BTNS-3, HZ2-BTNS-4, HZ2-BTNS-5, and HZ2-BTNS-6 button assemblies.

NOTE: The HZ2-AUX cannot be used to control a load directly. It must be used in conjunction with a HZ2-DIMEX, HZ2-DIMUEX, or HZ2-SWEX.

LED Indicator and Light Sensor

LED Feedback	None; For multiway control using a device that provides LED backlighting, use a HZ2-KPCN or HZ2-KPEX
Light Sensor	None; For multiway control using a device that has a light sensor, use a HZ2-KPCN or HZ2-KPEX

Wire Distance

Maximum wire length of 250 ft (77 m) between HZ2-AUX and Primary Device

Connections

Line	(1) Screw clamp terminal, consists of (2) wire inserts and (1) black screw head; Line power input; Accepts (1) 14-12 AWG wire per insert, do not insert wires behind screw head
Remote	(1) Screw clamp terminal, consists of (2) wire inserts and (1) blue screw head; Remote input from HZ2-AUX or HZ2-KPEX ; Accepts (1) 14-12 AWG wire per insert, do not insert wires behind screw head

Ground (1) 12 AWG flying lead, Class 1, green with yellow stripe;
Ground;
Wire nut included

Environmental

Temperature 32° to 86°F (0° to 30°C)
Humidity 10% to 90% RH (noncondensing)

Construction

Mounting Mounts in a 1- to 4-gang U.S. electrical box (not included);
3.5 in. (26 mm) electrical box depth recommended;
Derating required in multigang applications

Faceplate Requires a Horizon® 2 faceplate ([HZ2-FP-G](#), sold separately, metal backplate included with faceplate);
Multigang installations require a 2-, 3-, or 4-gang Horizon® 2 faceplate with metal backplate ([HZ2-FP-G](#), sold separately);
The metal backplate is required for all installations where the electrical box is flush with or recessed from the wall surface;
The metal backplate is not recommended for electrical boxes that protrude beyond the wall surface

Dimensions

Height 4.13 in. (105 mm)
Width 1.80 in. (46 mm)
Depth (Standard) 1.75 in. (45 mm) overall, extends 0.44 in. (12 mm) from wall surface when installed
Depth (Glass) 1.83 in. (47 mm) overall, extends 0.46 in. (12 mm) from wall surface when installed

Weight

7.4 oz (208 g)

Compliance

FCC, UL, IC

Regulatory Model: M201849006

1. Any infiNET EX device that provides expander functionality will effectively extend the range of the wireless network beyond the initial range of the gateway. Battery-powered infiNET EX devices do not provide expander functionality. A dedicated infiNET EX Wireless Expander, model CLW-EXPEX (sold separately), is also available.

Dimension Drawings

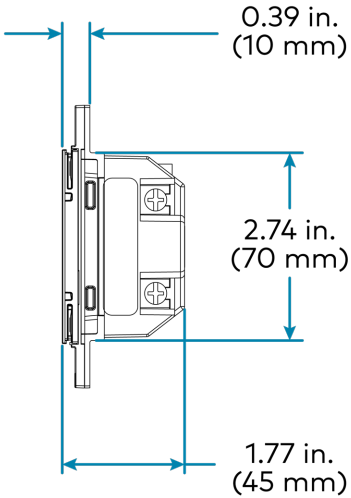
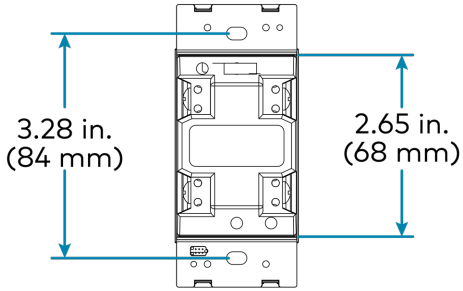
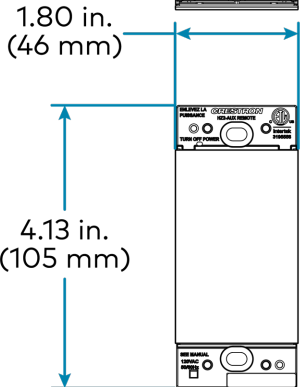
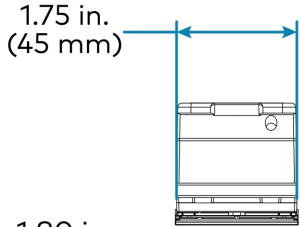

HZ2A-KEY Specifications

Product specifications for the HZ2A-KEY.

Product Specifications

Button Assembly

Connectors

HZ2A-KEY1:	(1) Keystone module position; Accepts flush-mount keystone connectors; Keystone connector not included
HZ2A-KEY2:	(2) Keystone module position; Accepts flush-mount keystone connectors; Keystone connector not included
HZ2A-KEY4:	(4) Keystone module position; Accepts flush-mount keystone connectors; Keystone connector not included
Mounting	Mounts in a 1- to 4-gang U.S. electrical box (not included); 3.5 in. (26 mm) electrical box depth recommended; Derating required in multigang applications

Construction

Keystone Plate	Plastic; White, almond, or black
Mounting	Mounts in a 1- to 4-gang U.S. electrical box or plaster ring (not included), gangable up to four units
Faceplate	Requires an HZ2-FP-G series faceplate (sold separately)

Dimensions

Height	4.13 in. (105 mm)
Width	1.80 in. (46 mm)
Depth	0.56 in. (15 mm)

Weight

7.4 oz (208 g)

Compliance

Dimension Drawings

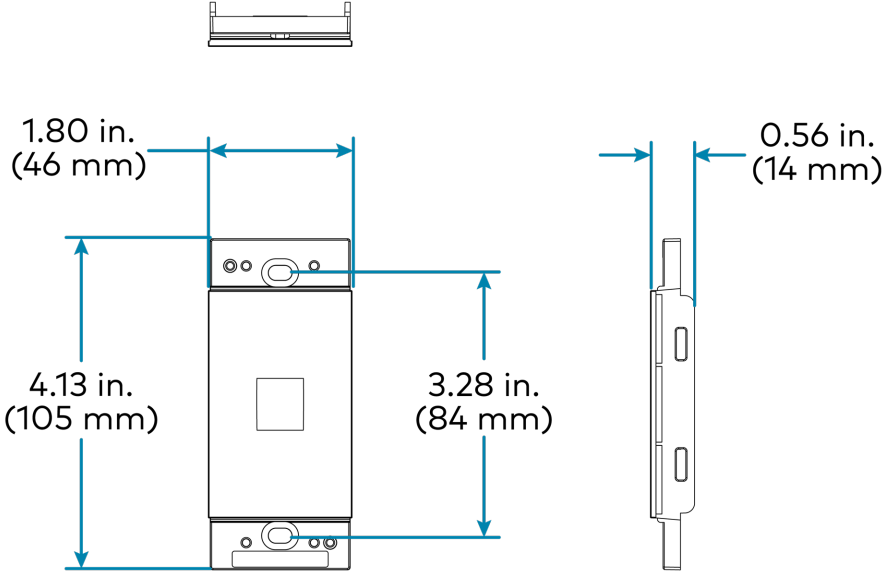

HZ2-FP-G Specifications

Product specifications for the HZ2-FP-G.

Product Specifications

Construction

Composition (Standard models)	Plastic; White, almond, or black; Textured
Composition (GLASS models)	Glass; White or black
Mounting	Attaches to Horizon devices mounted in a U.S. electrical box or plaster ring (not included); Includes a metal backplate to avoid mounting issues due to drywall or electrical box imperfections

Dimensions

Height	4.73 in. (120 mm)
Height (Decorator Opening)	2.64 in. (67 mm)
Width, 1-Gang	3.07 in. (78 mm)
Width, 2-Gang (Standard, Glass, D2)	4.88 in. (124 mm)
Width, 2-Gang (D1)	5.12 in. (130 mm)
Width, 3-Gang (Standard, Glass)	6.69 in. (170 mm)
Width, 3-Gang (D1)	6.93 in. (176 mm)
Width, 4-Gang (Standard, Glass)	8.50 in. (216 mm)
Width, 4-Gang (D1)	8.74 in. (222 mm)
Width (Decorator Opening)	1.32 in. (34 mm)
Depth (Standard and Decorator)	0.40 in. (10 mm)
Depth (Glass)	0.46 in. (12 mm)

Weight

7.4 oz (208 g)

Dimension Drawings

HZ2-FP-G1

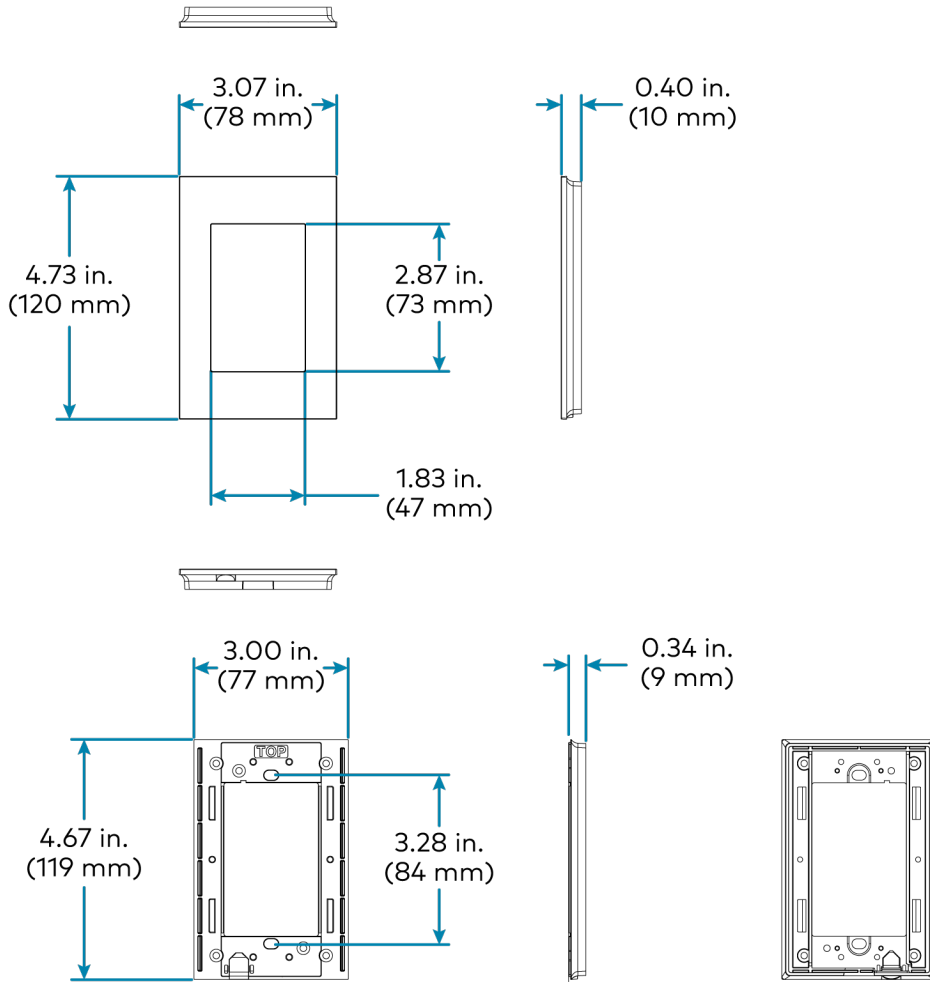

HZ2-FP-G2

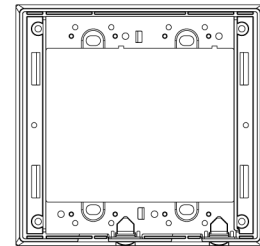
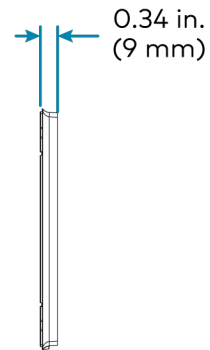
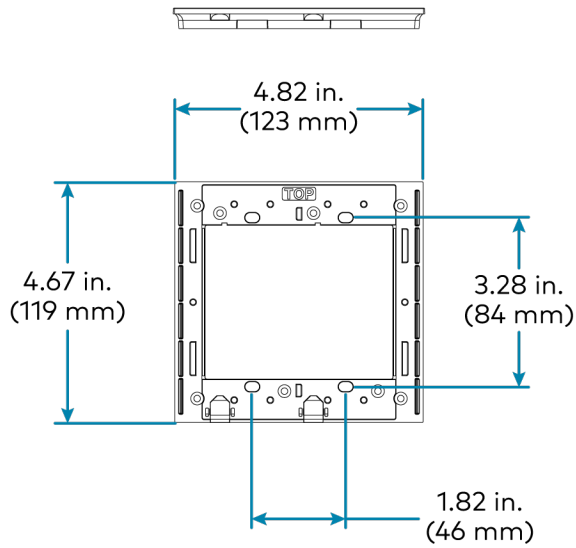
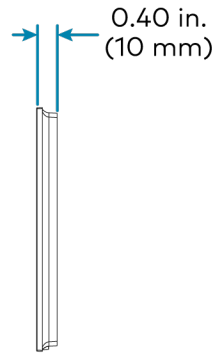
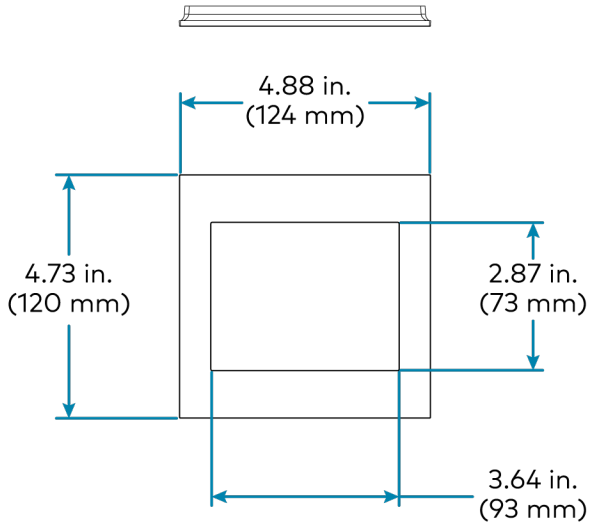

HZ2-FP-G3

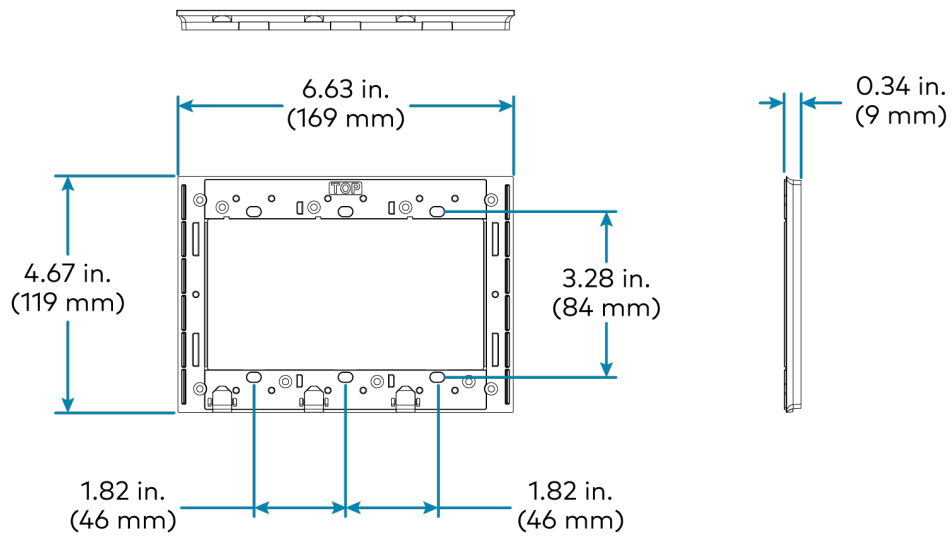
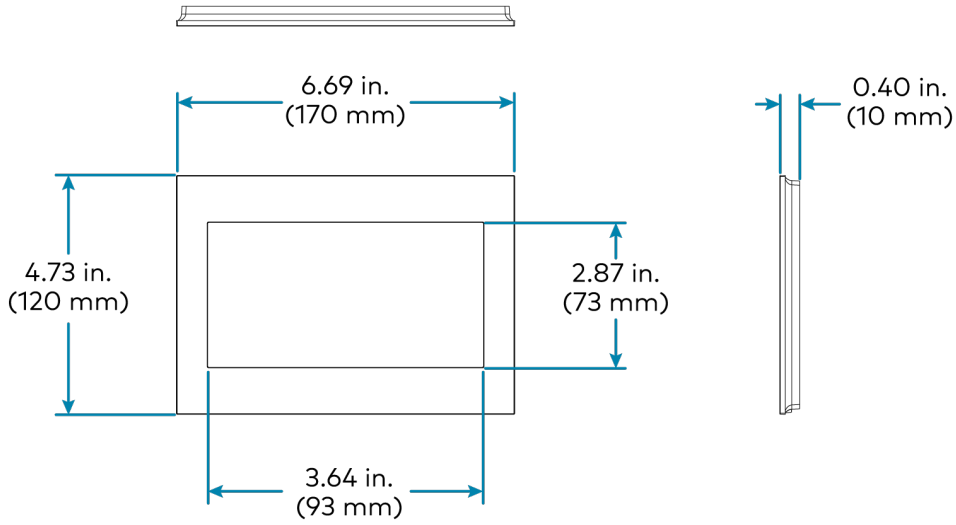

HZ2-FP-G4

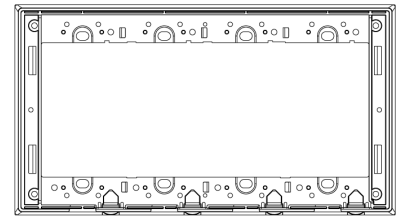
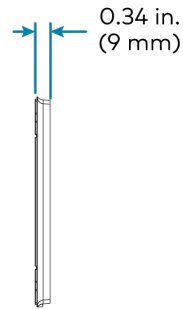
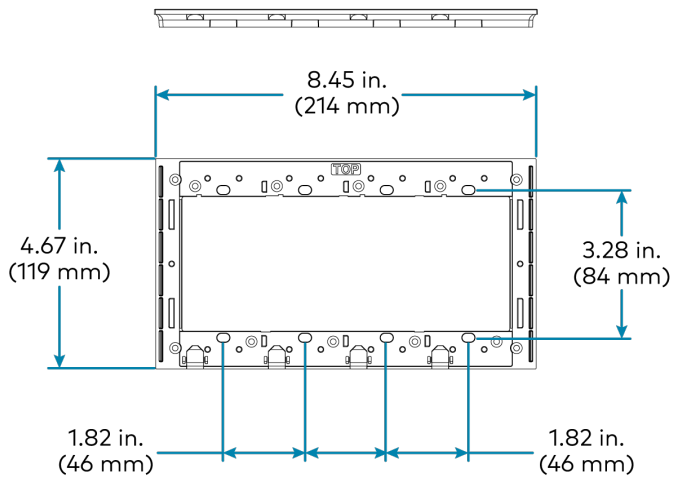
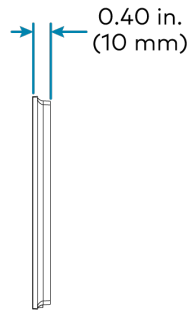
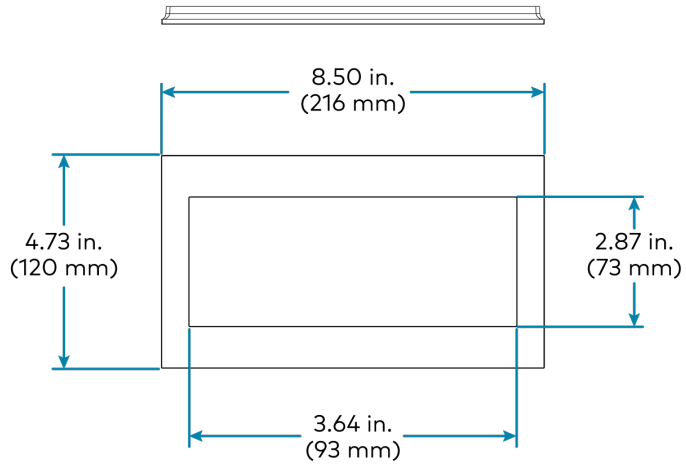

HZ2-FP-G1-D1

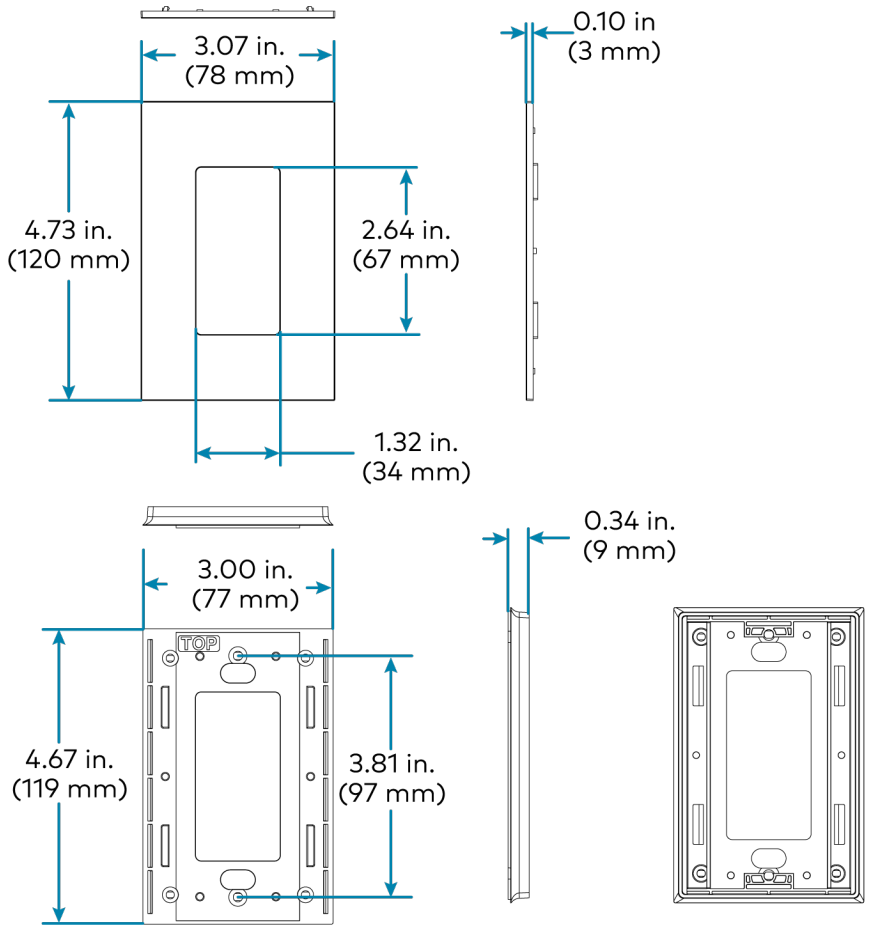

HZ2-FP-G2-D1

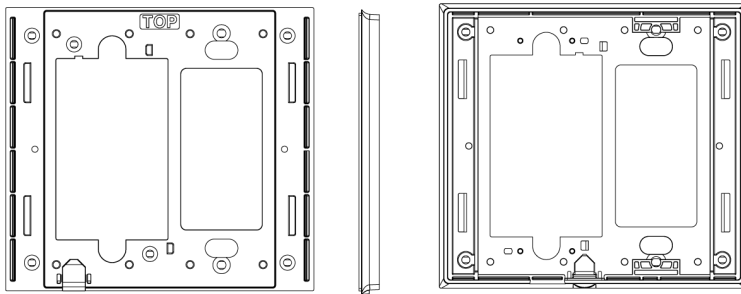
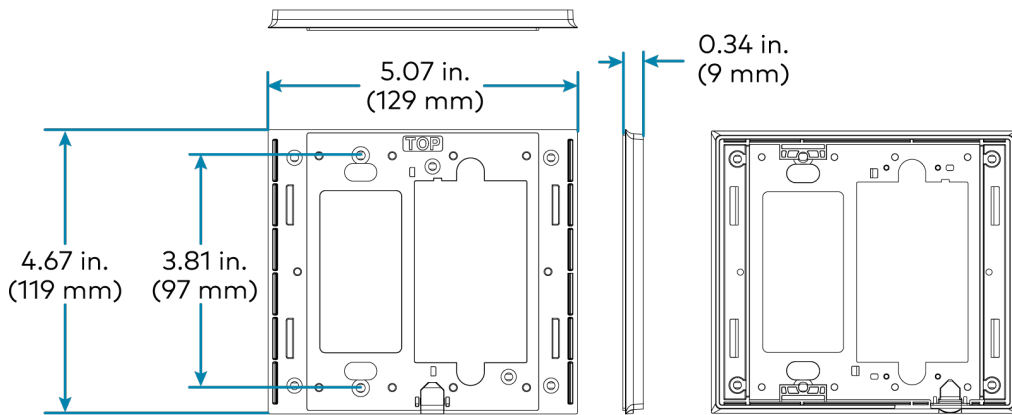
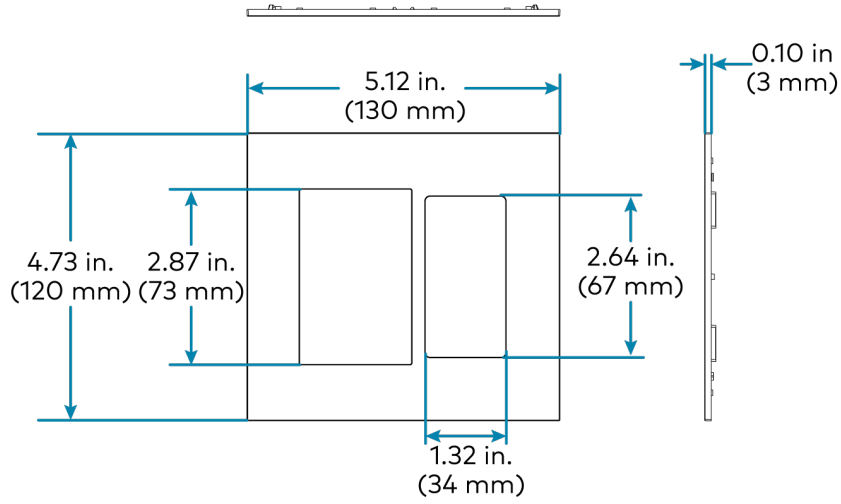

HZ2-FP-G2-D2

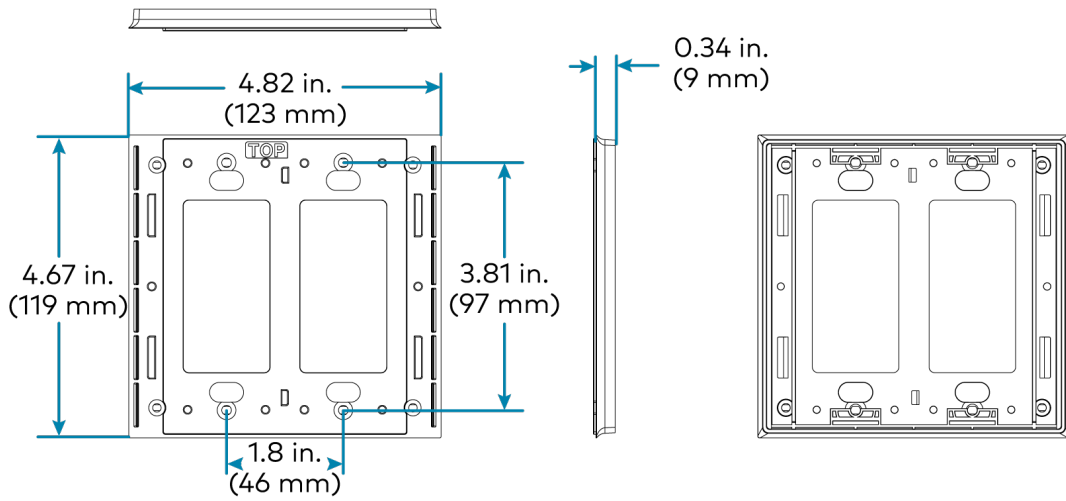
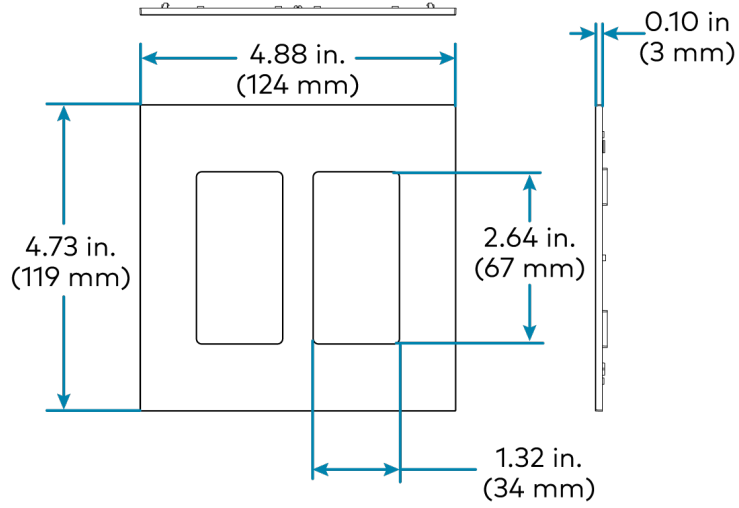

HZ2-FP-G3-D1

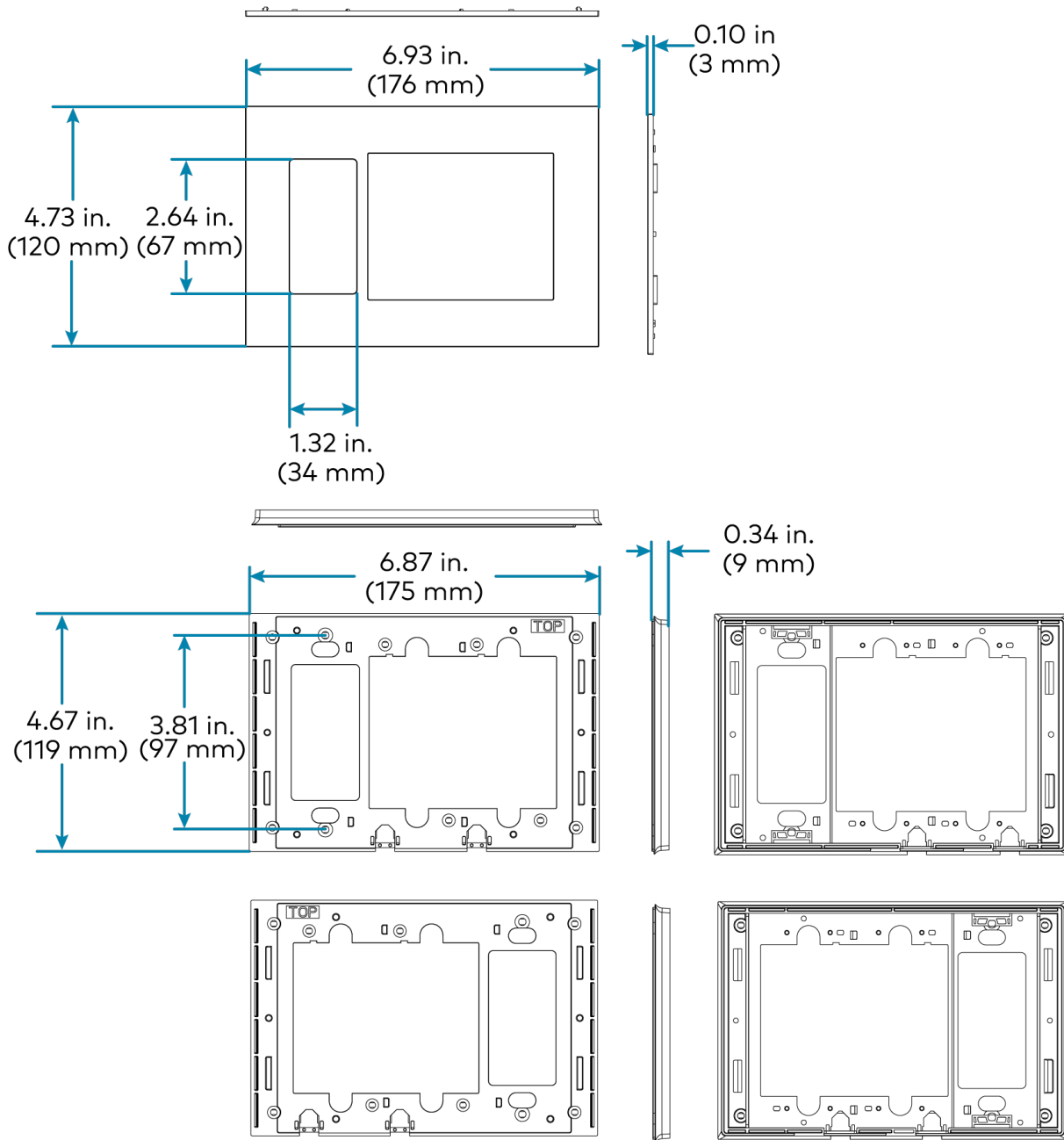

HZ2-FP-G4-D1

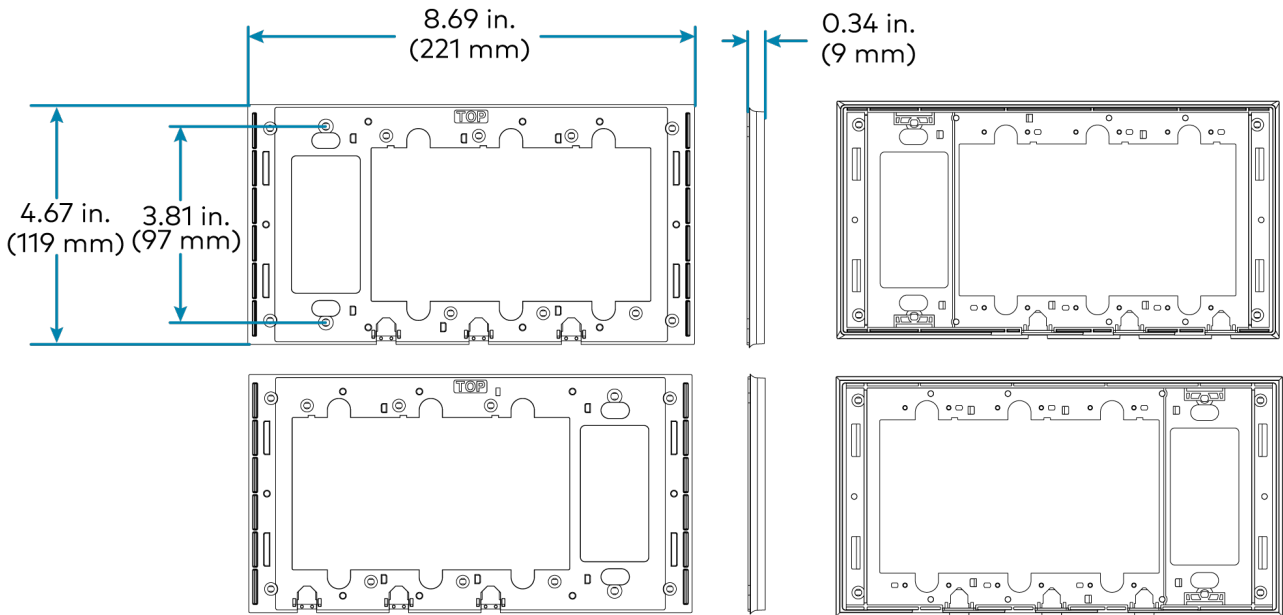
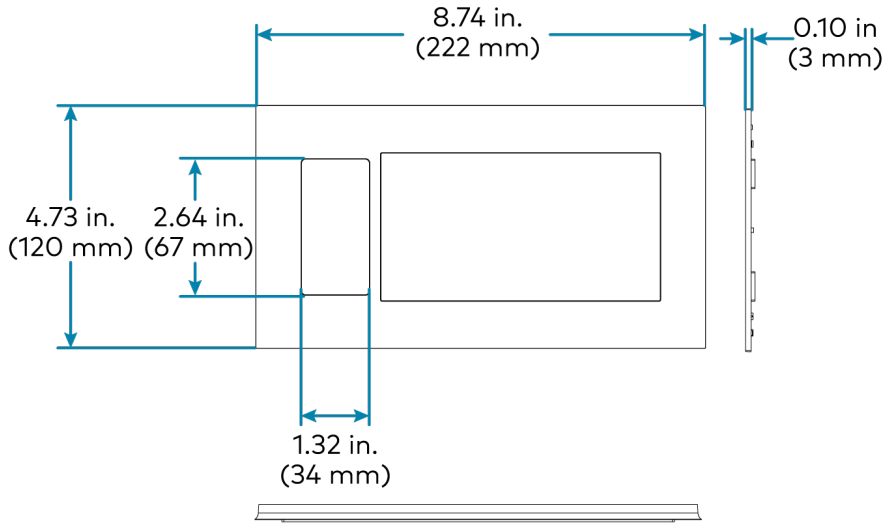

Installation

This section provides the following information:

- [In the Box](#)
- [Install the Batteries](#)
- [Prepare the HZ2-KPCN](#)

In the Box

Keypads

NOTE: The button assembly specified in the order is installed prior to shipment.

HZ2-DIMEX, HZ2-DIMUEX, HZ2-DIMLVEX, HZ2-SWEX, HZ2-AUX, and HZ2-KPEX

Qty.	Description
1	HZ2-DIMEX, Horizon® 2 In-Wall Forward-Phase Dimmer with infiNET EX® Wireless Communication, 120 VAC, HZ2-DIMUEX, Horizon® 2 In-Wall Universal Phase Dimmer with infiNET EX® Wireless Communication, 120 VAC, HZ2-SWEX, Horizon® 2 In-Wall Switch with infiNET EX® Wireless Communication, 120 VAC, HZ2-AUX, Horizon® 2 In-Wall, Multiway Remote, HZ2-KPEX, Horizon® 2 In-Wall Keypad with infiNET EX® Wireless Communication, 120 VAC, HZ2-KPEX, Horizon® In-Wall Keypad with infiNET EX® Wireless Communication, 120 VAC,
Additional Items	
2	Screw, 06-32 x 1 in. Truss, Combo (2054883)
1	Spacer, Plastic, Multi-Gang Alignment (2049924)
1	Wire nut, Plastic, Blue (2045230)

HZ2-DIMLVEX

Qty.	Description
1	HZ2-DIMLVEX, Horizon® 2 In-Wall 0-10V Dimmer with infiNET EX® Wireless Communication, 120 VAC
Additional Items	
2	Screw, 06-32 x 1 in. Truss, Combo (2054883)
1	Spacer, Plastic, Multi-Gang Alignment (2049924)
5	Wire nut, Plastic, Blue (2045230)
1	Wire nut, Plastic, Red (2053634)

HZ2-KPCN

Qty.	Description
1	HZ2-KPCN, Horizon® 2 Keypad with Cresnet® Communications

Qty.	Description
Additional Items	
2	Screw, 06-32 x 1 in. Truss Head, Combo (2054883)
6	Screw, 04-40 x .25 in., Flat Head, Phillips (2050242)
2	Screw, 3 x 12 mm, Flat Head, Phillips (2034889)
1	Faceplate, Front*
1	Faceplate, Rear*
2	Connector, 4-pin (2003576)
1	Connector, 3-pin (2003575)
1	Metal, Bracket, Mounting (2058573)

* Available in white (-W), almond (-A), and black (-B). Please refer to the Crestron website for a complete list of models and colors.

Faceplates

HZ2-FP-G1

Qty.	Description
1	HZ2-FP-G1, Horizon® 2 Faceplate, 1-Gang
Additional Items	
6	Screw, 04-40 x .25 in., Flat Head, Phillips (2050242)
1	Metal, Bracket, Top, 1-Gang (2057778)
1	Metal, Bracket, Bottom, 1-Gang (2057779)

HZ2-FP-G2

Qty.	Description
1	HZ2-FP-G2, Horizon® 2 Faceplate, 2-Gang
Additional Items	
8	Screw, 04-40 x .25 in., Flat Head, Phillips (2050242)
1	Metal, Bracket, Top, 2-Gang (2057780)
1	Metal, Bracket, Bottom, 2-Gang (2057781)
1	Spacer, Plastic, Multi-Gang Alignment (2049924)

HZ2-FP-G3

Qty.	Description
1	HZ2-FP-G3, Horizon® 2 Faceplate, 3-Gang

Qty.	Description
Additional Items	
10	Screw, 04-40 x .25 in., Flat Head, Phillips (2050242)
1	Metal, Bracket, Top, 3-Gang (2057782)
1	Metal, Bracket, Bottom, 3-Gang (2057783)
2	Spacer, Plastic, Multi-Gang Alignment (2049924)

HZ2-FP-G4

Qty.	Description
1	HZ2-FP-G4, Horizon® 2 Faceplate, 4-Gang
Additional Items	
12	Screw, 04-40 x .25 in., Flat Head, Phillips (2050242)
1	Metal, Bracket, Top, 4-Gang (2057784)
1	Metal, Bracket, Bottom, 4-Gang (2057785)
3	Spacer, Plastic, Multi-Gang Alignment (2049924)

HZ2-FP-G1-D1

Qty.	Description
1	HZ2-FP-G1-D1, Horizon® 2 Faceplate, 1-Gang, 1-Decorator
Additional Items	
4	Screw, 04-40 x .25 in., Flat Head, Phillips (2050242)
2	Screw, 06-32 x .31 in., Flat Head, Phillips (2062159)
1	Metal, Bracket, Top, 1-Gang (2063028)
1	Metal, Bracket, Bottom, 1-Gang (2063029)

HZ2-FP-G2-D1

Qty.	Description
1	HZ2-FP-G2-D1, Horizon® 2 Faceplate, 2-Gang, 1-Decorator (includes plates for left and right decorator mounting)
Additional Items	
6	Screw, 04-40 x .25 in., Flat Head, Phillips (2050242)
2	Screw, 06-32 x .31 in., Flat Head, Phillips (2062159)

Qty.	Description
1	Metal, Bracket, Top, 2-Gang, 1-Decorator (2061453)
1	Metal, Bracket, Bottom, 2-Gang, 1-Decorator (2061454)

HZ2-FP-G2-D2

Qty.	Description
1	HZ2-FP-G2-D2, Horizon® 2 Faceplate, 2-Gang, 2-Decorator

Additional Items

4	Screw, 04-40 x .25 in., Flat Head, Phillips (2050242)
4	Screw, 06-32 x .31 in., Flat Head, Phillips (2062159)
1	Metal, Bracket, Top, 2-Gang, 2-Decorator(206030)
1	Metal, Bracket, Bottom, 2-Gang, 2-Decorator(2063031)

HZ2-FP-G3-D1

Qty.	Description
1	HZ2-FP-G3-D1, Horizon® 2 Faceplate, 3-Gang, 1-Decorator (includes plates for left and right decorator mounting)

Additional Items

8	Screw, 04-40 x .25 in., Flat Head, Phillips (2050242)
2	Screw, 06-32 x .31 in., Flat Head, Phillips (2062159)
1	Metal, Bracket, Top, 3-Gang, 1-Decorator (2061455)
1	Metal, Bracket, Bottom, 3-Gang, 1-Decorator (2061456)
1	Spacer, Plastic, Multi-Gang Alignment (2049924)

HZ2-FP-G4-D1

Qty.	Description
1	HZ2-FP-G4-D1, Horizon® 2 Faceplate, 4-Gang, 1-Decorator (includes plates for left and right decorator mounting)

Additional Items

10	Screw, 04-40 x .25 in., Flat Head, Phillips (2050242)
2	Screw, 06-32 x .31 in., Flat Head, Phillips (2062159)
1	Metal, Bracket, Top, 4-Gang, 1-Decorator (2061457)
1	Metal, Bracket, Bottom, 4-Gang, 1-Decorator (2061458)
2	Spacer, Plastic, Multi-Gang Alignment (2049924)

* Please refer to the Crestron website for a complete list of models and colors.

Mounting

Mount the Horizon® 2 device to an electrical box.

- To install the HZ2-DIMEX, HZ2-DIMLVEX, HZ2-DIMUJEX, HZ2-KPEX, HZ2-SWEX, and HZ2-AUX, refer to [Horizon 2 Line Voltage Devices and Multi-Gang Installation on page 86](#).
- To install the HZ2-KPCN, refer to [HZ2-KPCN Mounting on page 98](#) or [HZ2-KPCN Mounting in an EU Backbox on page 105](#).
- To install the HZ2A-KEY, refer to [Mounting on page 86](#).
- To install the metal backplate with the device in place, refer to [Post-Installation Metal Backplate Assembly on page 111](#).

TIP: Consider the following when using the metal backplate:

- The metal backplate is required for all installations where the electrical box is flush with or recessed from the wall surface. This is common for installation into New Work boxes.
- The metal backplate is not recommended for electrical boxes that protrude beyond the wall surface.
- If the room contains both New Work and Old Work boxes, it may be necessary to use the metal backplate for all devices to maintain a consistent appearance.
- The two-piece metal backplate can be installed after the Horizon® 2 devices are installed. This may occur if the faceplate is not onsite at the time of the keypad installation. For details, refer to [Post-Installation Metal Backplate Assembly on page 111](#).
- Two styles of metal backplates are offered. The one-piece metal backplate is supplied along with the faceplate for the HZ2-KPCN and the two-piece metal backplates are supplied with the 1-, 2-, 3-, and 4-gang HZ2-FP-G series faceplates.

Horizon 2 Line Voltage Devices and Multi-Gang Installation

To install the Horizon® 2 device:

NOTE: To wire the device, refer to [Wiring on page 115](#).

1. Turn power off at the circuit breaker.

WARNING: If the device is used with an HZ2-AUX or HZ2-KPEX, power may need to be turned off at multiple breakers.

2. For multi-gang installations, insert one multi-gang alignment spacer between each device.

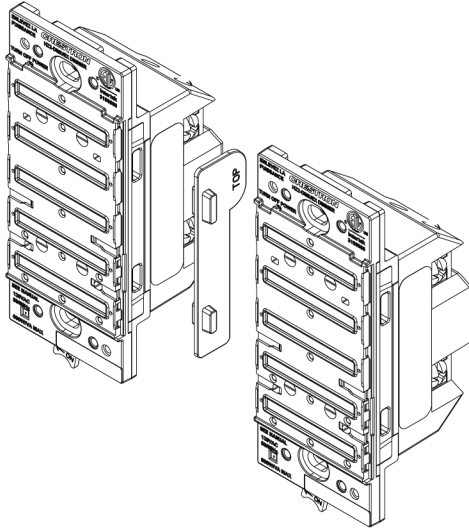

- Secure the device to the electrical box using two #06-32 x 1 in. combo head mounting screws (2054883). To allow for adjustments and installation of the metal bracket, do not fully tighten the mounting screws at this time. Ensure the device is in the proper orientation with any text facing up.

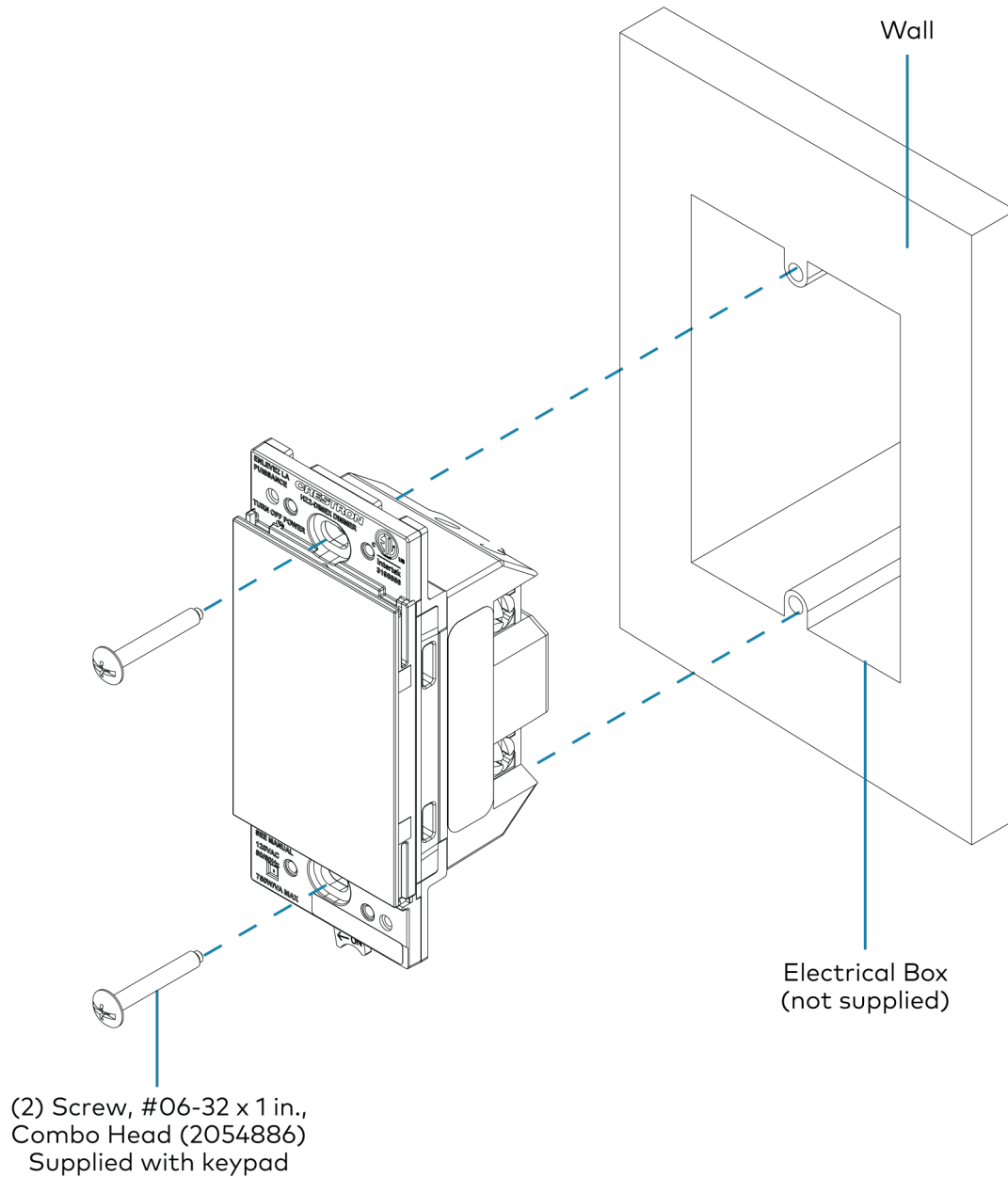

- Place the top of the metal bracket (supplied with faceplate) over the back of the device and then insert the bottom of the metal bracket under the back of the device. Connect the top and bottom metal bracket by hanging the bottom bracket on the tabs on the top metal bracket. The two parts of the metal bracket clip together which allows the wiring to remain in place.

NOTE: If the electrical box extends beyond the wall, the metal bracket can be left off to prevent a gap between the wall and the faceplate.

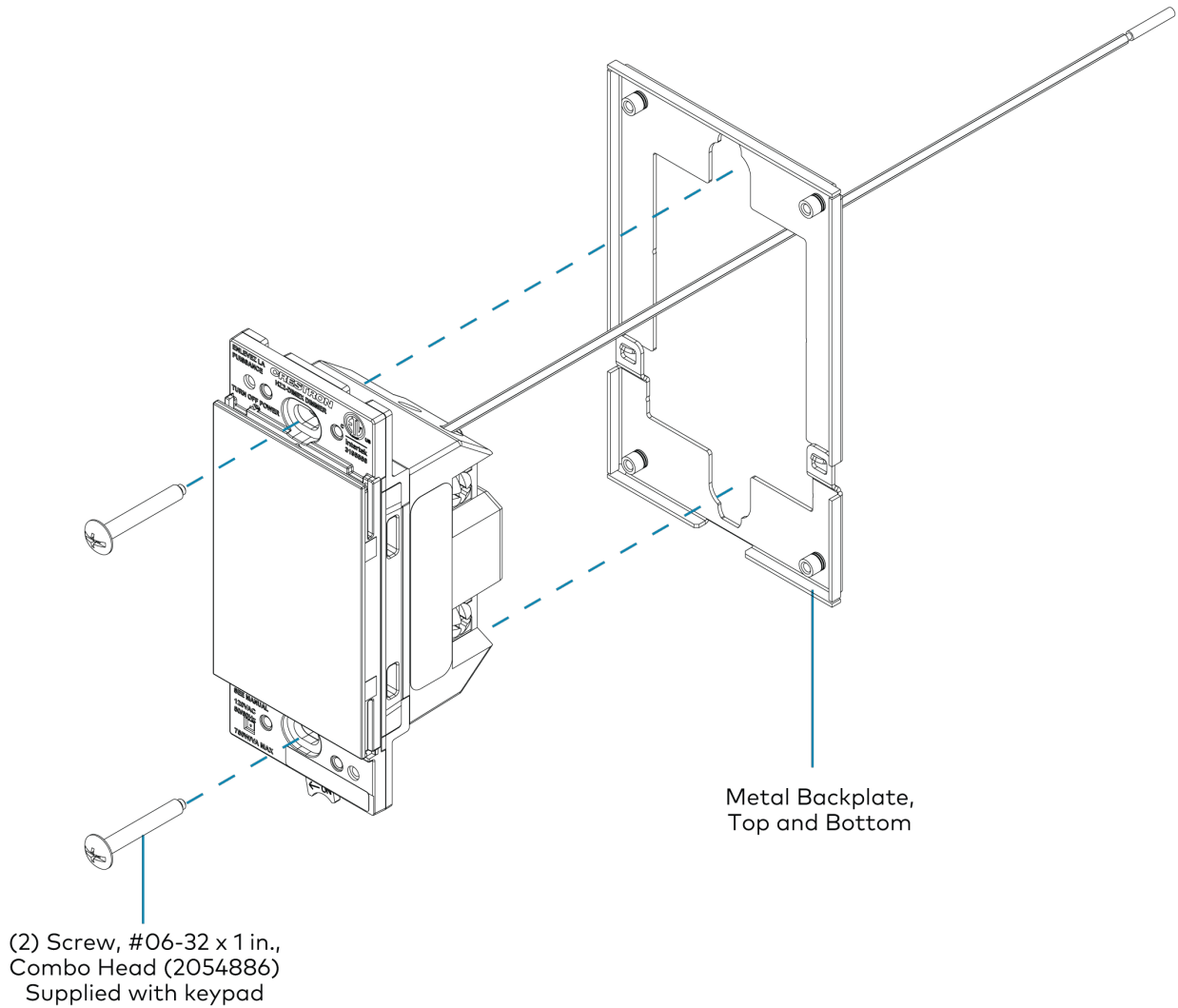

5. Attach the rear of the faceplate to the device using two #04-40 x 0.25 in. screws (2050242). For multi-gang installations, use two screws per device. The rear of the faceplate provides access to the mounting screws.

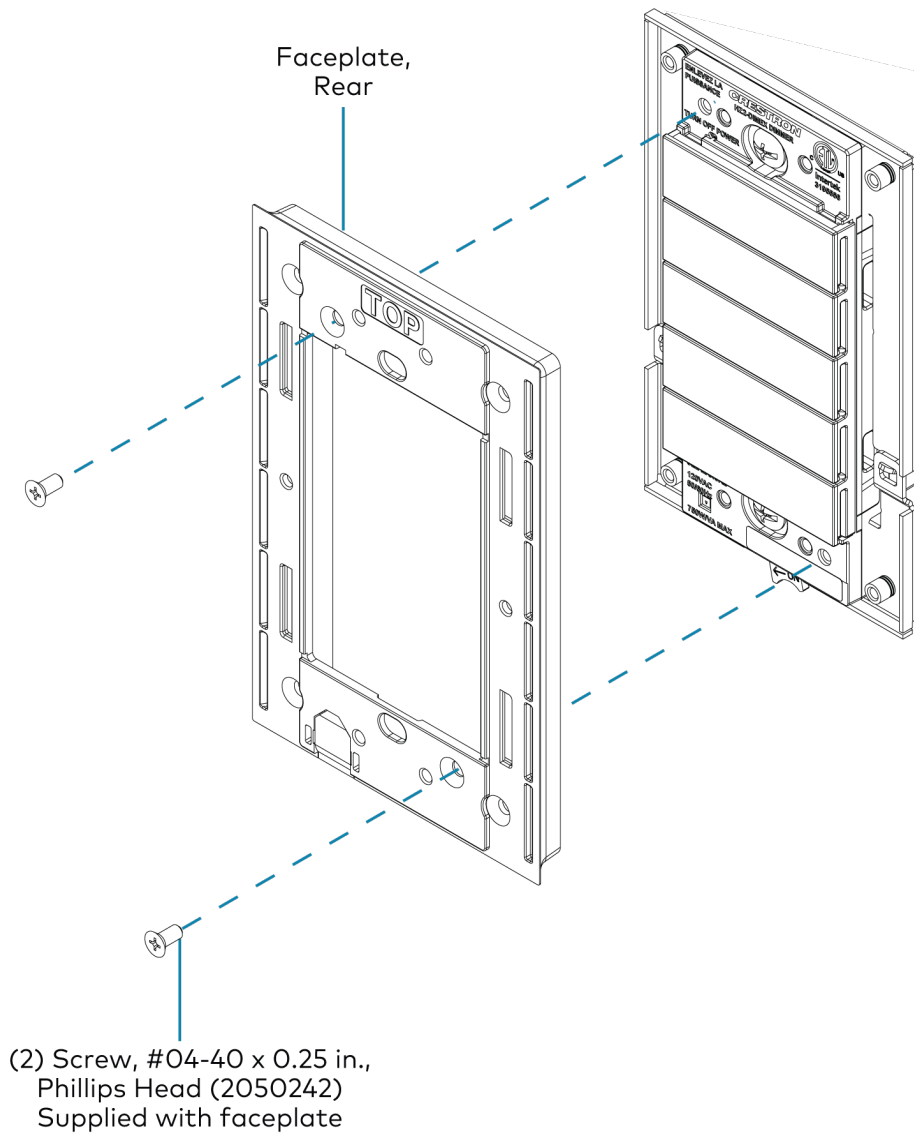

6. Secure the rear of the faceplate to the metal backplate using four 04-40 x 0.25 in. screws (2050242).

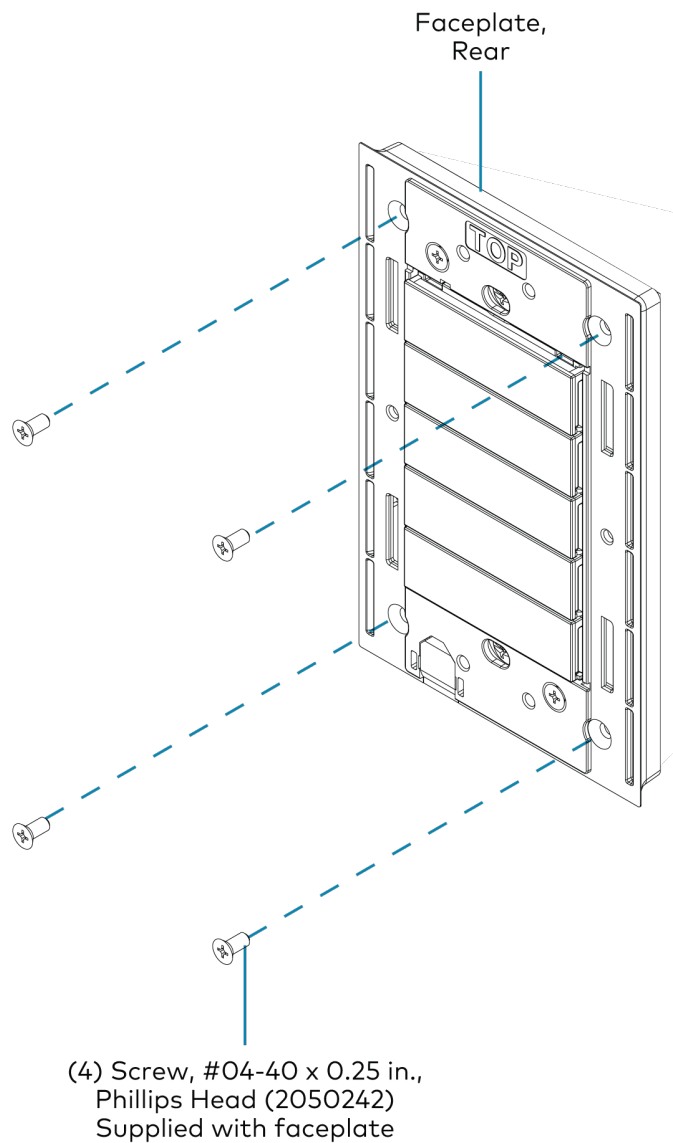

7. Ensure that the device is properly aligned within the faceplate and then fully tighten the two #06-32 x 1 in. combo head mounting screws (2054883) to secure the device to the electrical box.

CAUTION: Do not overtighten the screws when attaching the device to the electrical box. Damage to the unit and undesired functionality may occur.

8. Snap the faceplate front onto the faceplate rear.

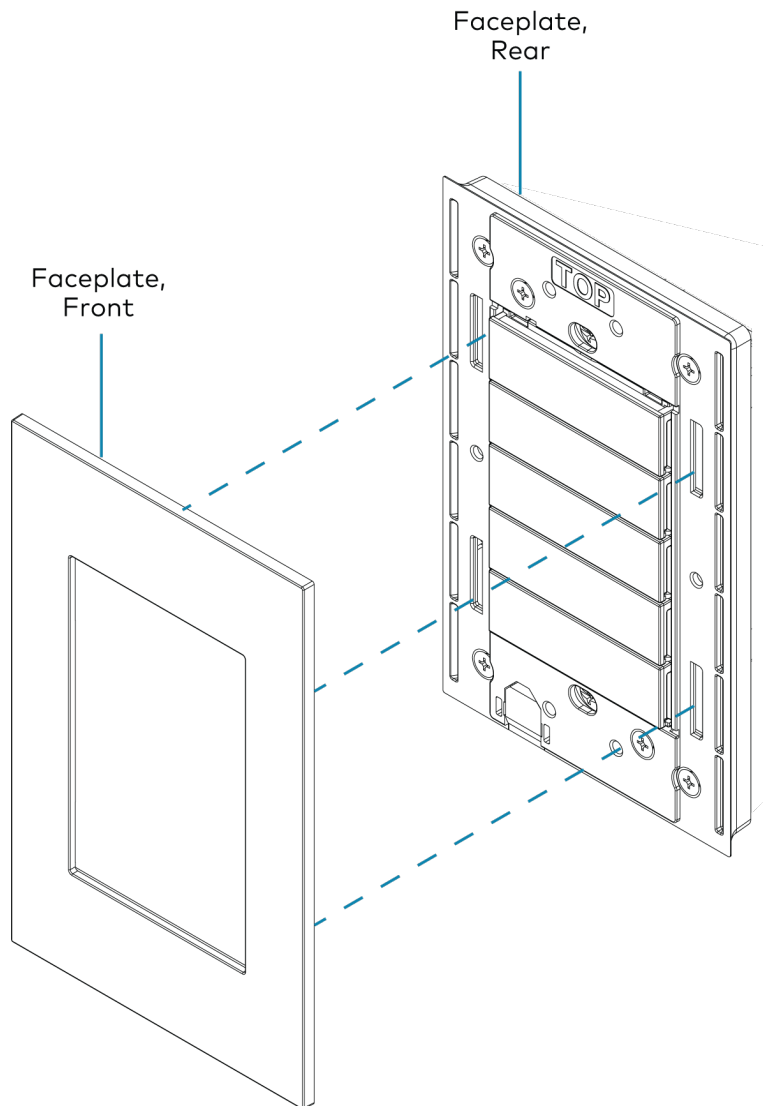

9. Test each button to make sure that they actuate without sticking.
10. Restore power at the circuit breaker.

HZ2-DIMUEX Installation using 2-Gang Faceplate

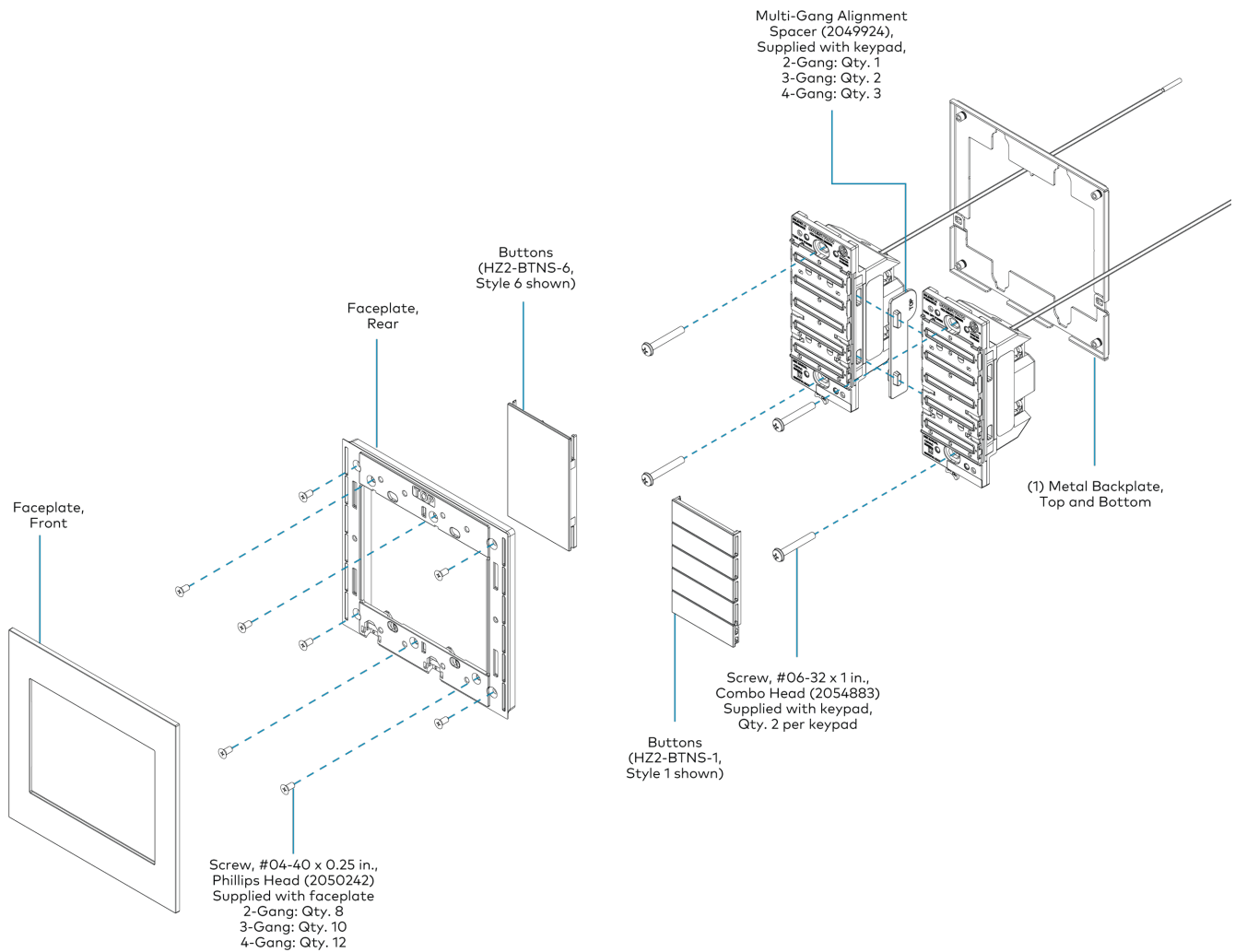

Decorator Faceplate Mounting

To install the Horizon® 2 device when using a Decorator faceplate, follow the instructions below.

NOTE: To wire the device, refer to [Wiring on page 115](#).

1. Turn power off at the circuit breaker.

WARNING: If the device is used with an HZ2-AUX or HZ2-KPEX, power may need to be turned off at multiple breakers.

2. For multi-gang installations, insert one multi-gang alignment spacer between each Horizon device.

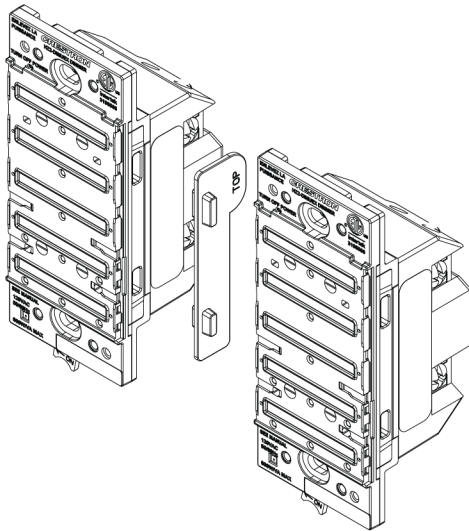

3. Secure the Horizon device(s) to the electrical box using two #06-32 x 1 in. combo head mounting screws (2054883). Secure the decorator-style device to the electrical box using the mounting screws provided with the decorator-style device. To allow for adjustments and installation of the metal bracket, do not fully tighten the mounting screws at this time. Ensure the devices are in the proper orientation with text facing up.

- Place the top of the metal bracket (supplied with faceplate) over the back of the device(s) and then insert the bottom of the metal bracket under the back of the device. Connect the top and bottom metal brackets by hanging the bottom bracket on the tabs on the top metal bracket. The two parts of the metal bracket clip together which allows the wiring to remain in place.

NOTES:

- If the electrical box extends beyond the wall, the metal bracket can be left off to prevent a gap between the wall and the faceplate.
- If using a faceplate that allows mounting the decorator style device on the left or right side, and you wish to mount the decorator style device on the left hand side, the metal bracket should be rotated 180 degrees from the typical installation orientation.

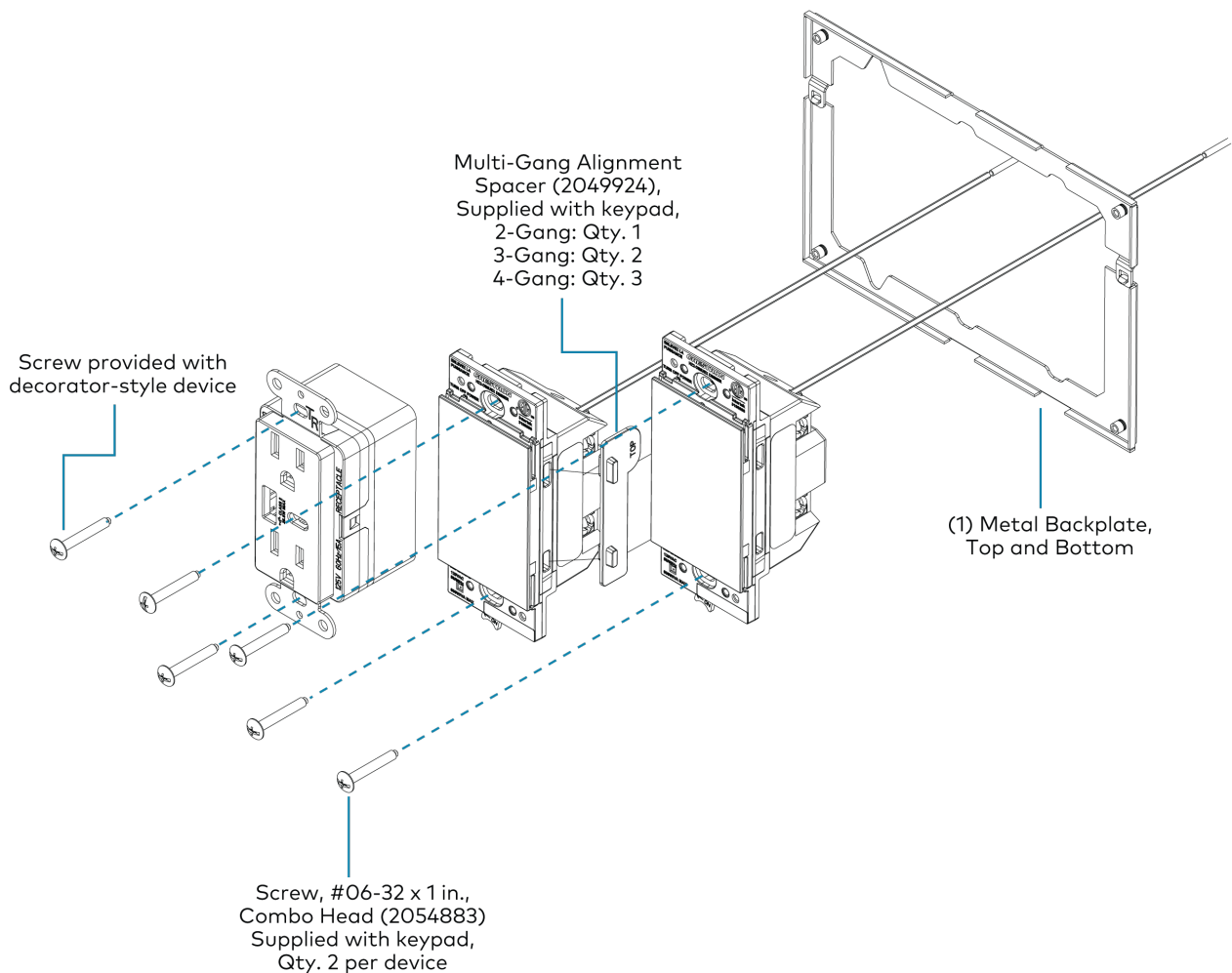

5. Attach the rear of the faceplate to the device(s) using two #04-40 x 0.25 in. screws (2050242) for each Horizon device and two #06-32 x 5/16 in. screws (2062159) for the decorator style device. If you are using a faceplate that allows mounting the decorator style device on the left or right hand side, use the faceplate rear matching the selected decorator mounting side.

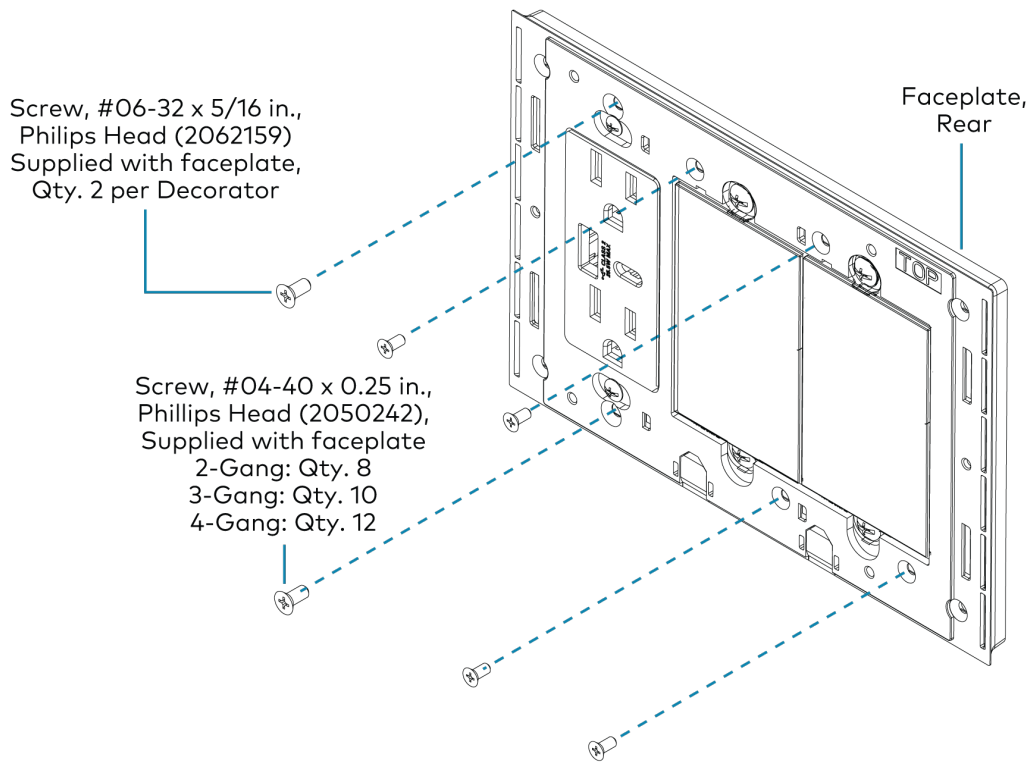

- Secure the rear of the faceplate to the metal backplate using four #04-40 x 0.25 in. screws (2050242).

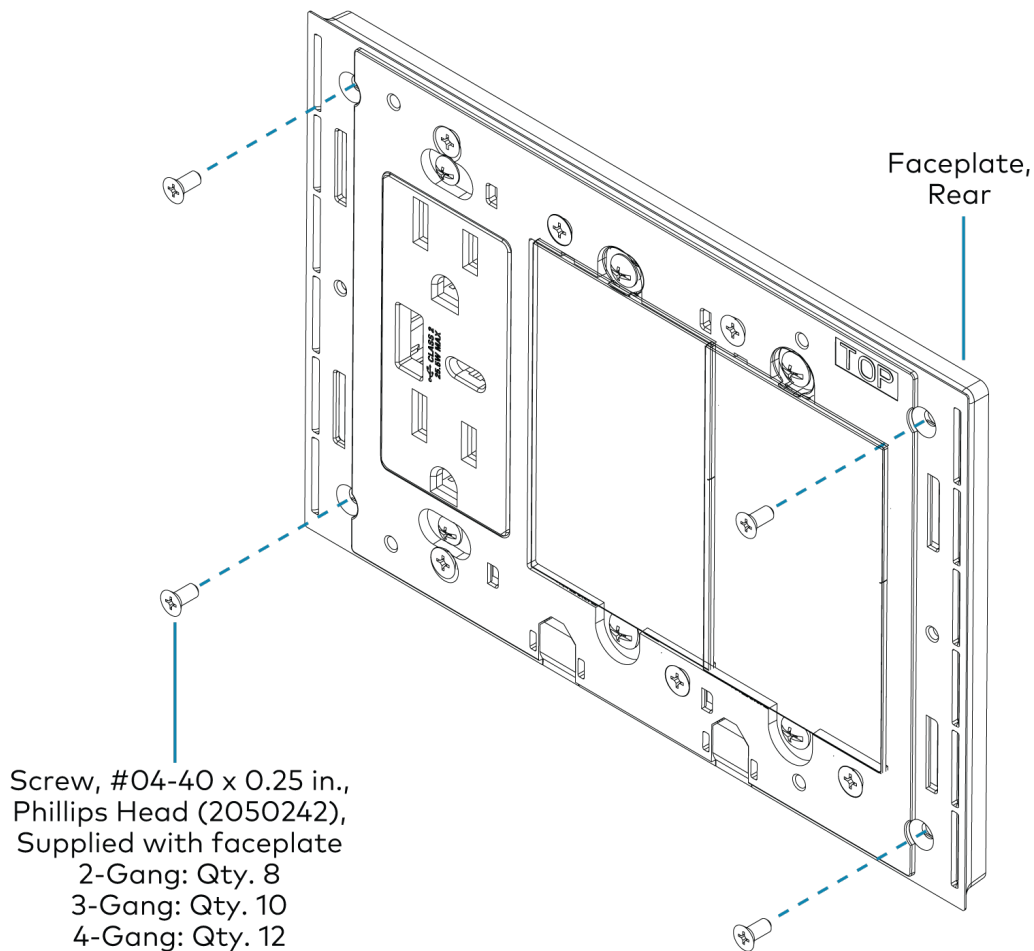

- Ensure that the assembly is properly aligned and level. Fully tighten the #06-32 x 1 in. combo head mounting screws (2054883) and mounting screws provided with the decorator style device to secure the device(s) to the electrical box.

CAUTION: Do not overtighten the screws when attaching the device to the electrical box. Damage to the unit and undesired functionality may occur.

- Snap the faceplate front onto the faceplate rear.
- Test each button to make sure that they actuate without sticking.
- Restore power at the circuit breaker.

HZ2-DIMUEX Installation using 3-Gang, 1-Decorator Faceplate

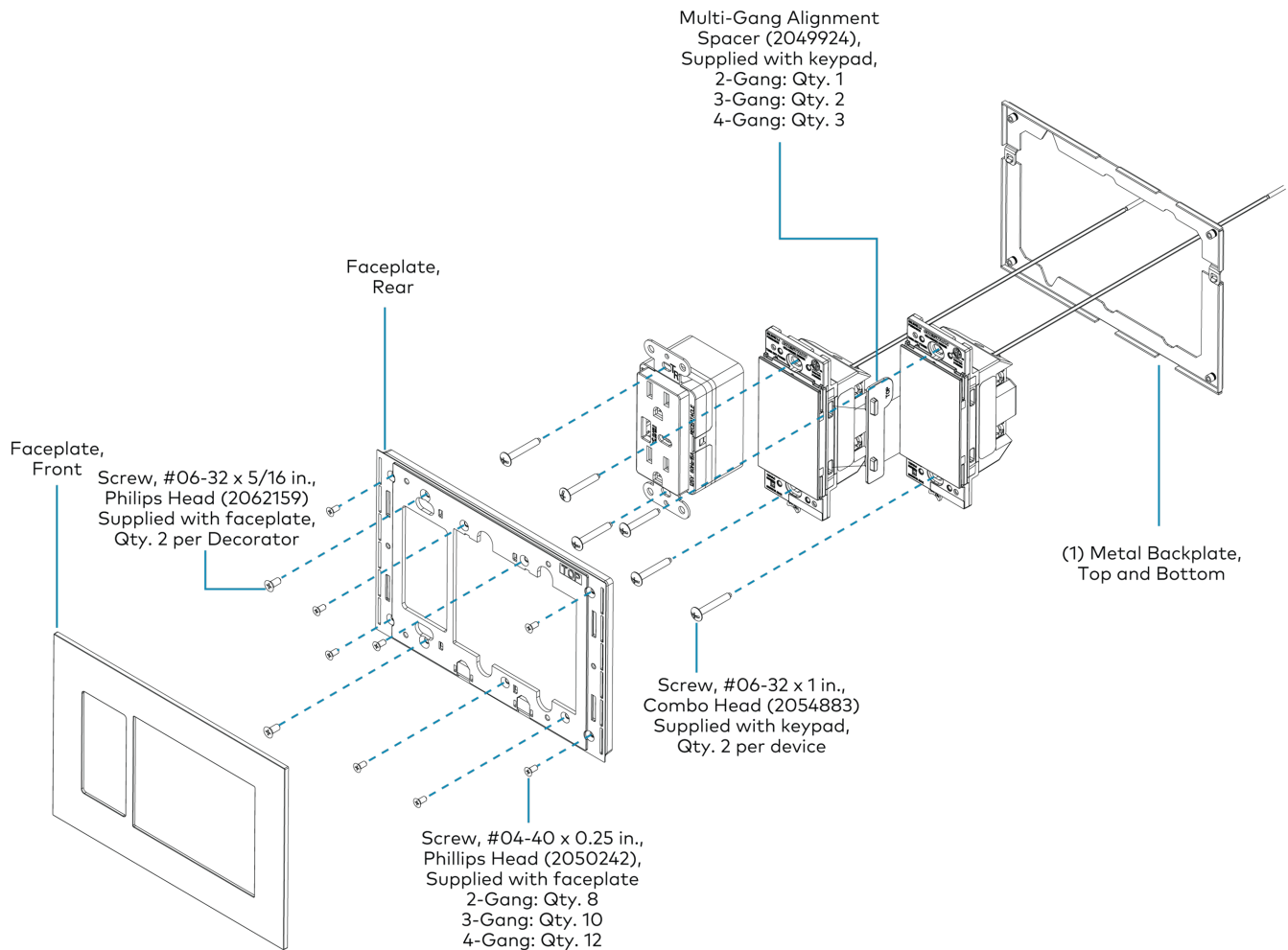

HZ2-KPCN Mounting

Mount the HZ2-KPCN with the included metal backplate (2058573) and faceplate in a 1-gang US-style backbox.

To mount the HZ2-KPCN in a 1-gang EU-style back box, refer to [HZ2-KPCN Mounting in an EU Backbox on page 105](#).

NOTE: To install the HZ2-KPCN with a 1-gang Horizon® 2 faceplate that is sold separately or in a multi-gang installation, refer to [Horizon 2 Line Voltage Devices and Multi-Gang Installation on page 86](#).

To install the HZ2-KPCN into a 1-gang US-style backbox with the one-piece backplate:

NOTE: To wire the device, refer to [Wiring on page 115](#).

1. Turn power off to the device.
2. For the HZ2-KPCN with supplied metal backplate, place the backplate over the back of the device. Make sure that the **Top** label is properly oriented.

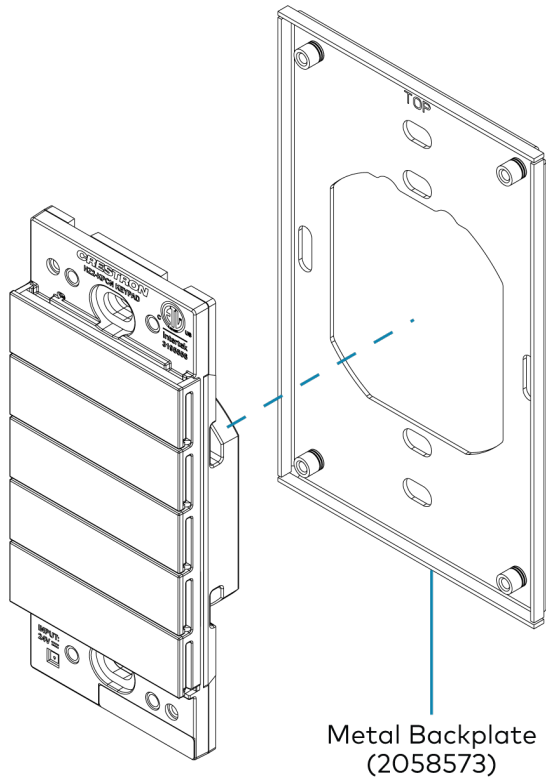

3. Secure the device and the metal backplate to the electrical box using the #06-32 x 1 in. combo head mounting screws (2054886). To allow for adjustments, do not fully tighten the screws at this time. Ensure the device is in the proper orientation with any text facing up.

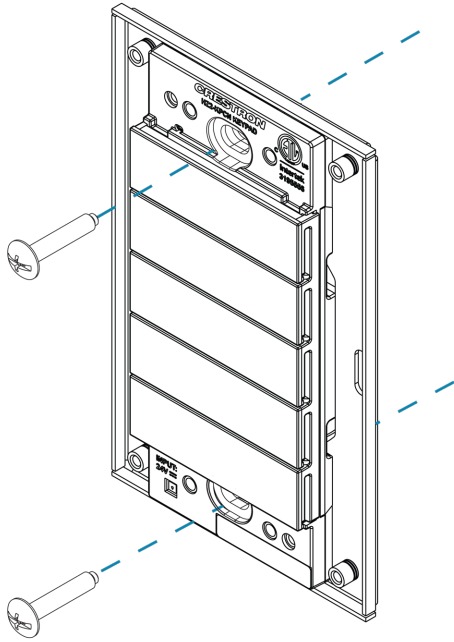

4. Attach the metal backplate to the device using two #04-40 x 0.25 in. screws (2050242).

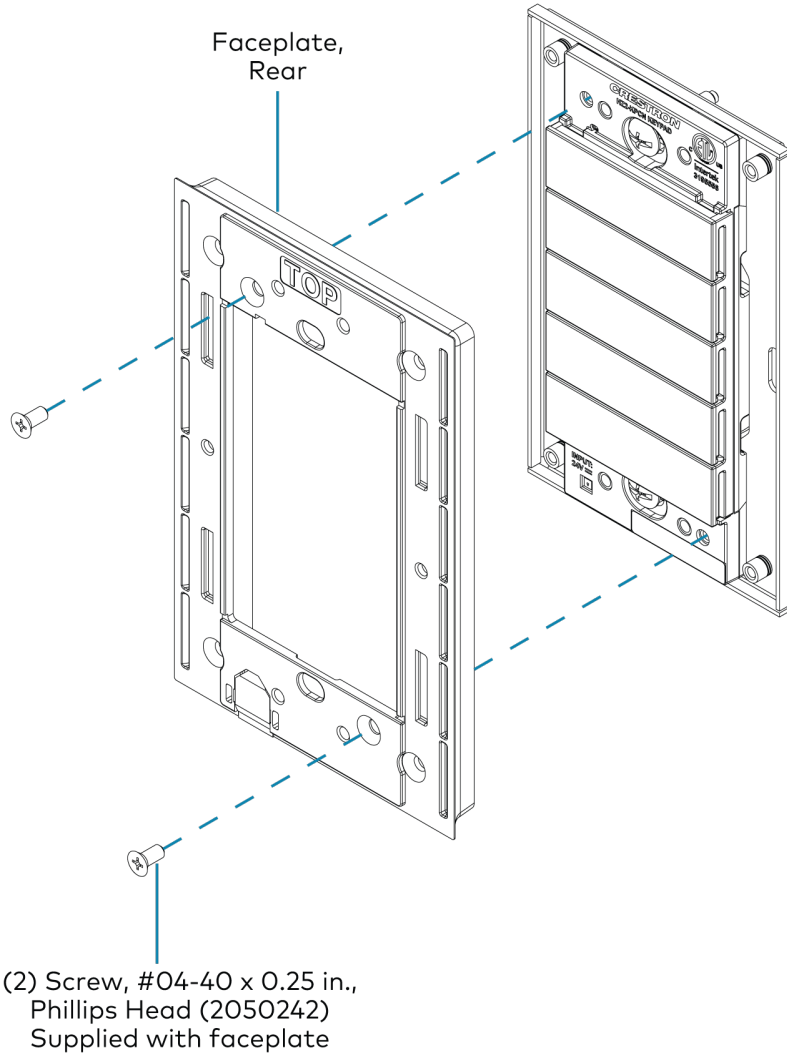

5. Secure the rear of the faceplate to the metal backplate using four 04-40 x 0.25 in. screws (2050242). The metal backplate is used to align the devices and ensure that they are level. Use a level to ensure that the metal backplate remains level during installation.

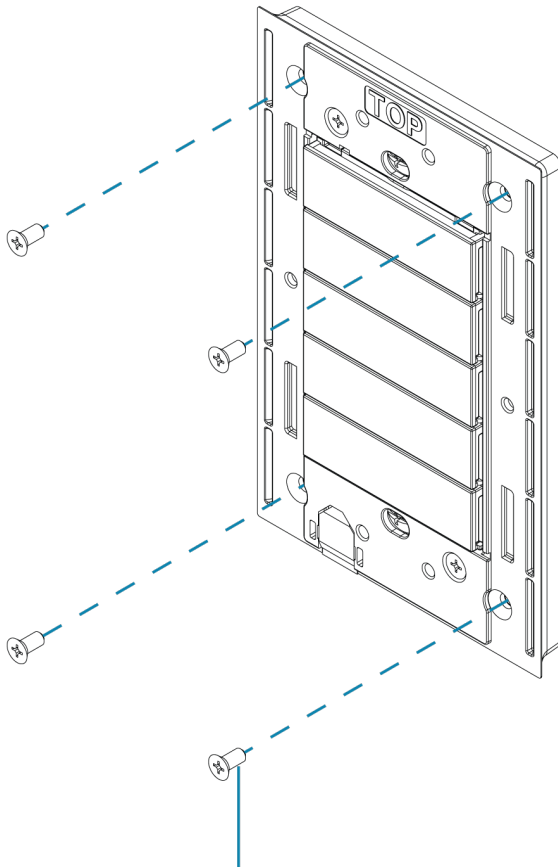

(4) Screw, #04-40 x 0.25 in.,
Phillips Head (2050242)
Supplied with faceplate

6. Ensure that the device is properly aligned within the faceplate and then fully tighten the mounting screws to secure the device to the electrical box.

CAUTION: Do not overtighten the screws when attaching the device to the electrical box. Damage to the unit and undesired functionality may occur.

7. Snap the front of the faceplate onto the rear of the faceplate. Ensure that all snaps fully engage.

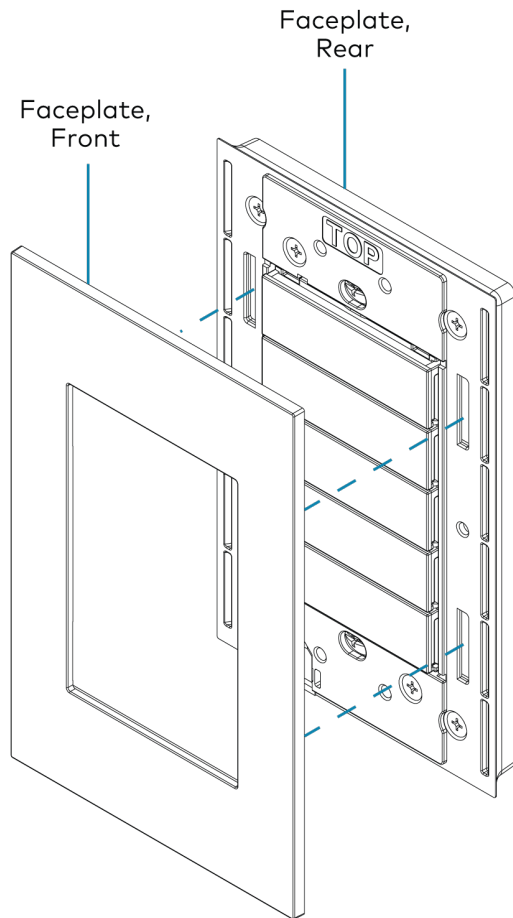

8. Ensure that all buttons actuate without sticking.
9. Restore power to the device.

HZ2-KPCN Installation using Supplied 1-Gang Faceplate and Metal Bracket

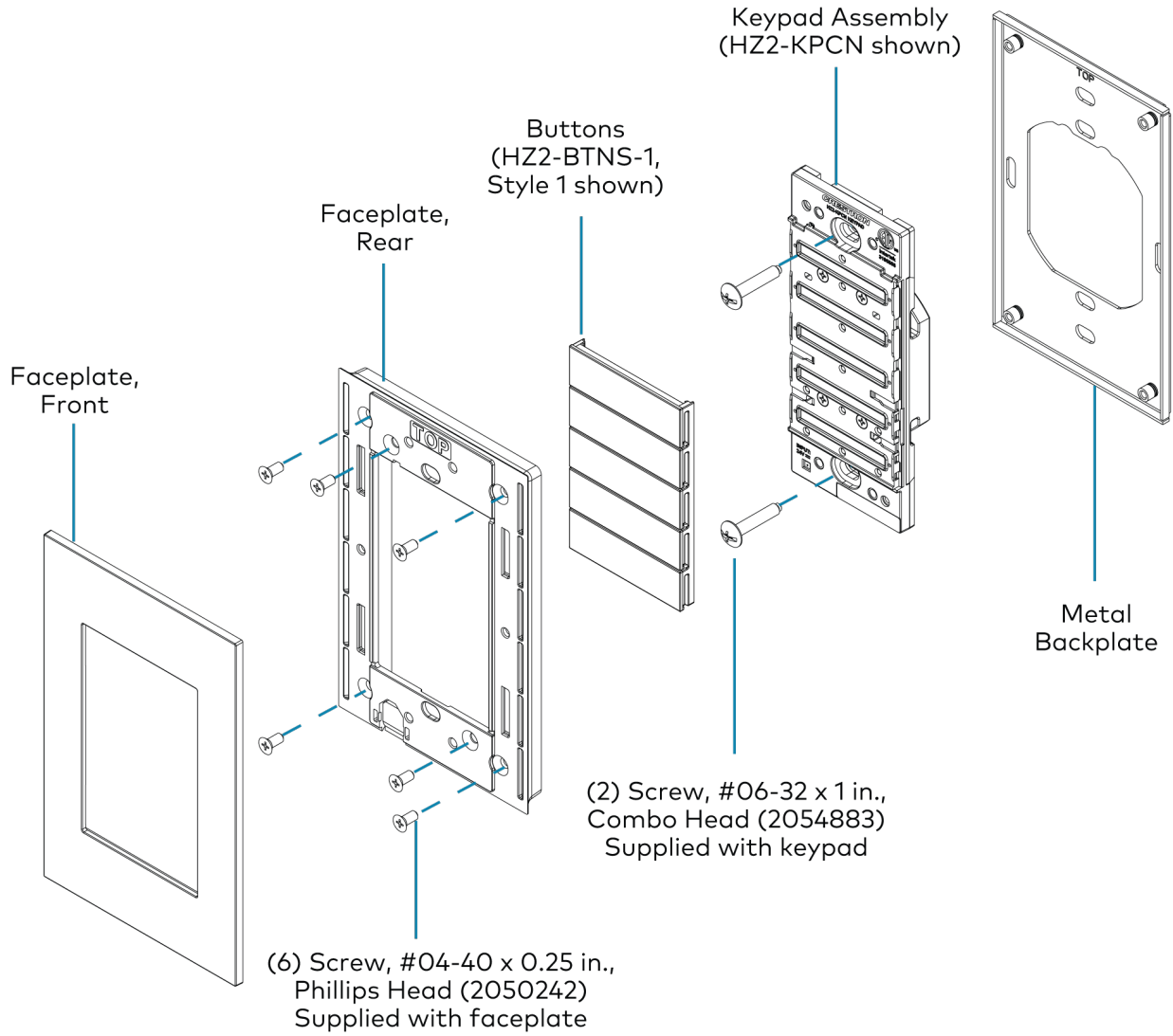

HZ2-KPCN Mounting in an EU Backbox

To mount the HZ2-KPCN in an EU-style back box, use the supplied metal bracket (2058573).

To install the HZ2-KPCN in a 1-gang EU backbox:

NOTE: To wire the device, refer to [Wiring on page 115](#).

1. Turn power off to the device.
2. Secure the metal backplate (2058573) to the electrical box using two 3 x 12 mm flat head Phillips mounting screws (2034889). Use the inner mounting holes on the metal backplate. If the electrical box is installed sideways, use the mounting holes on the sides of the keypad to maintain the vertical orientation of the keypad. Ensure the device is in the proper orientation with any text facing up. Use a level to make sure that the metal backplate remains level during installation.

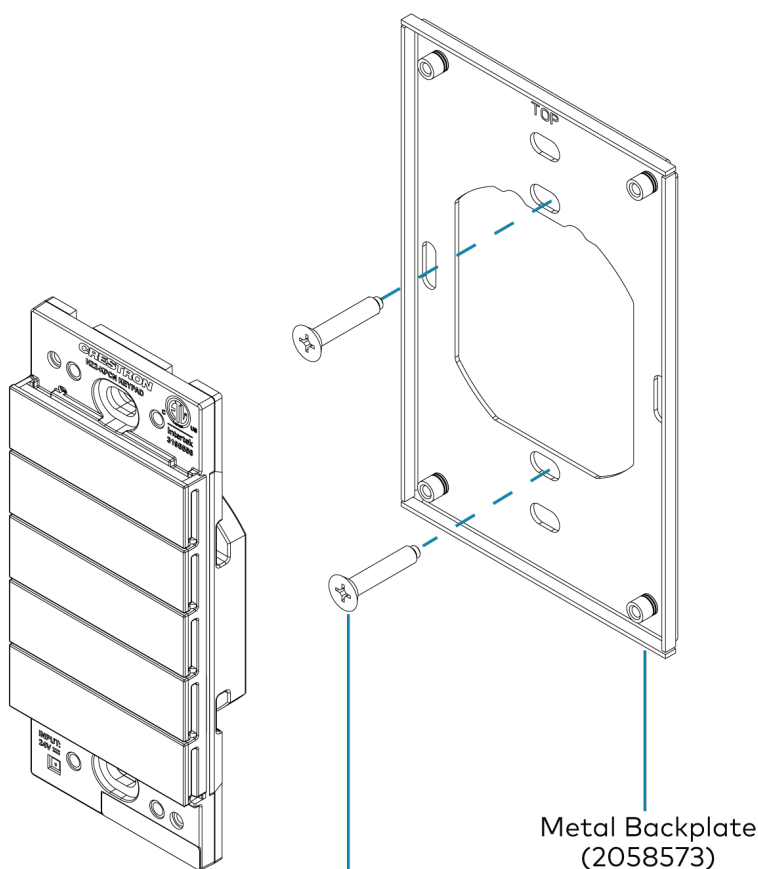

(2) Screw, 3 x 12 mm, Flat Head,
Phillips (2034889)
Supplied with keypad

3. Attach the rear of the faceplate to the HZ2-KPCN and the metal backplate using six #04-40 x 0.25 in. Phillips head screws (2050242). The mounting holes on the HZ2-KPCN are not used.

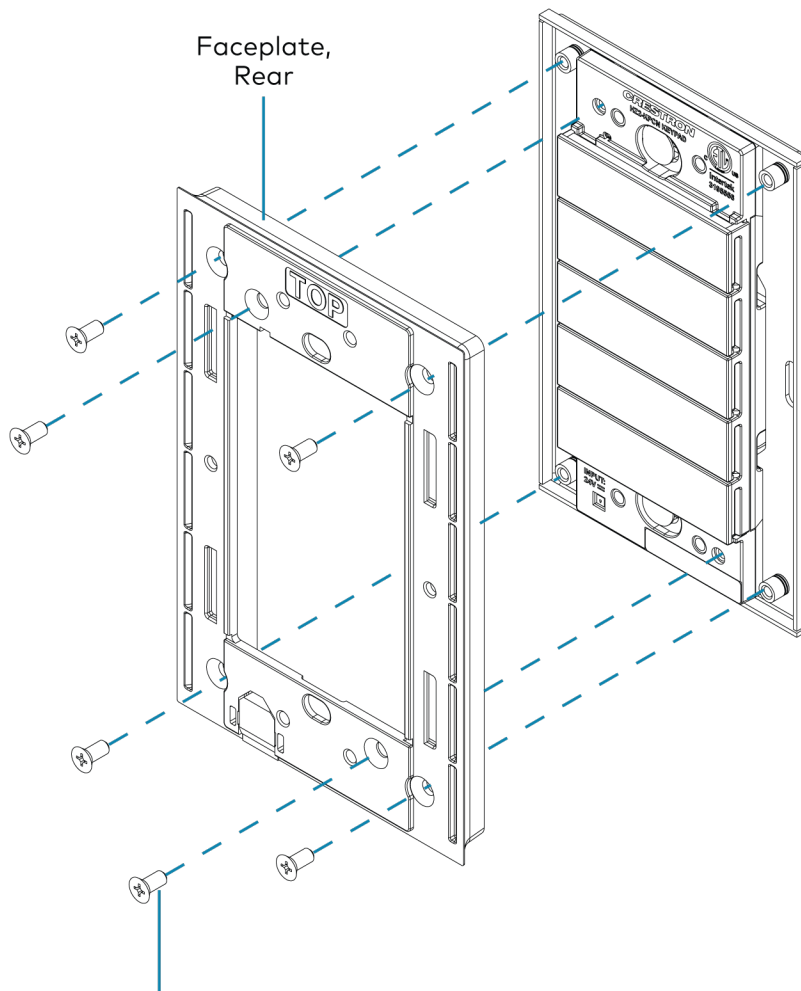

(6) Screw, #04-40 x 0.25 in.,
Phillips Head (2050242)
Supplied with faceplate

4. Snap the front of the faceplate onto the rear of the faceplate. Ensure that all snaps fully engage.

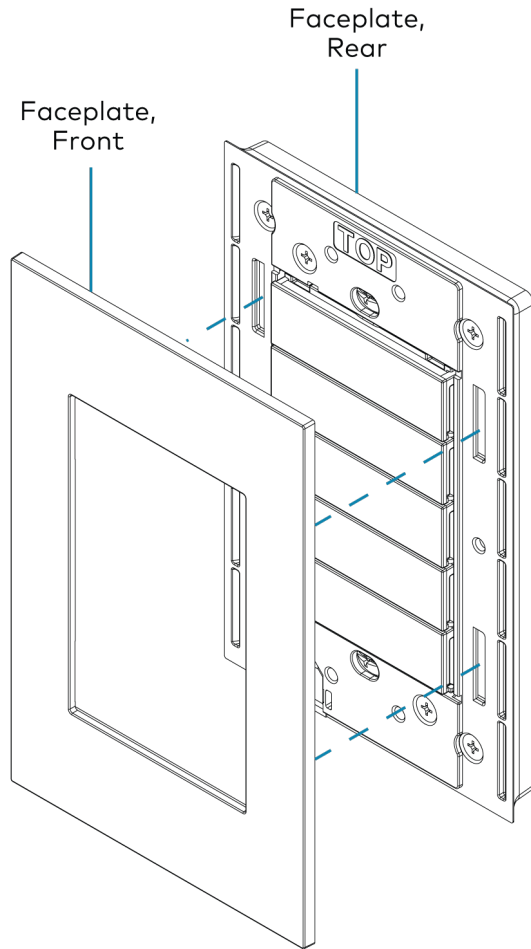

5. Ensure that all buttons actuate without sticking.
6. Restore power to the device.

HZ2A-KEY Mounting

Install the Keystone Module

Make all necessary connections to keystone module (not supplied) prior to installation. For details, refer to the documentation provided with the keystone module.

To install the keystone module:

1. Place the lip of the keystone module over the lip in the opening of the HZ2A-KEY.
2. Tilt the keystone module up until the top of the module lines up with the rear of the HZ2A-KEY.
3. Press the keystone module into the rear of the HZ2A-KEY. The keystone module snaps into place.

HZ2A-KEY Installation using 1-Gang Faceplate

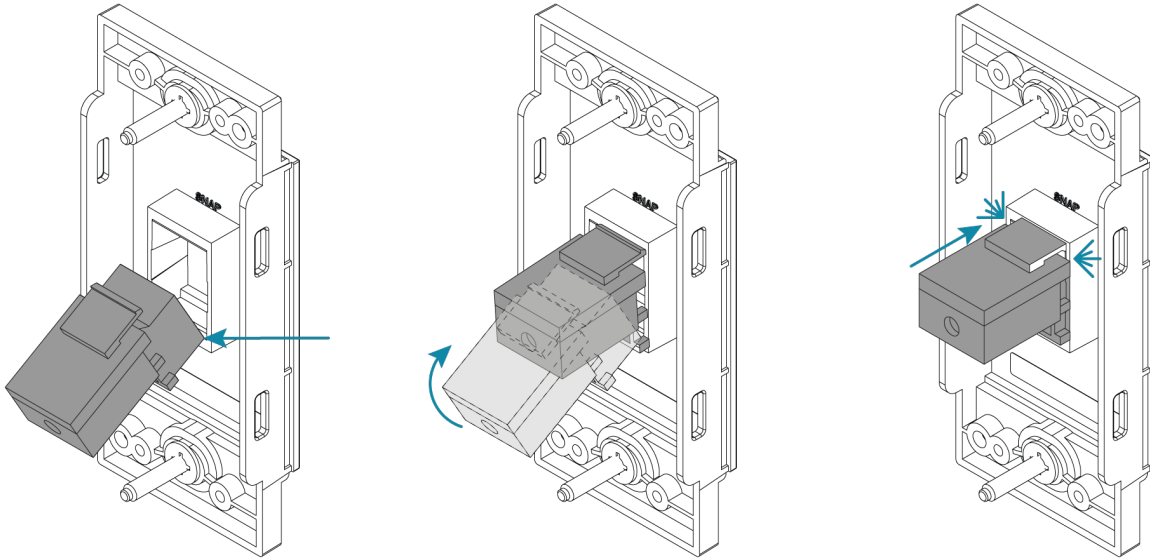

Install the HZ2A-KEY

To install an HZ2A-KEY device:

NOTE: Class 1 and Class 2 wiring must be kept separate if installing in a multi-gang box.

1. For multi-gang installations, insert one multi-gang alignment spacer between each device.

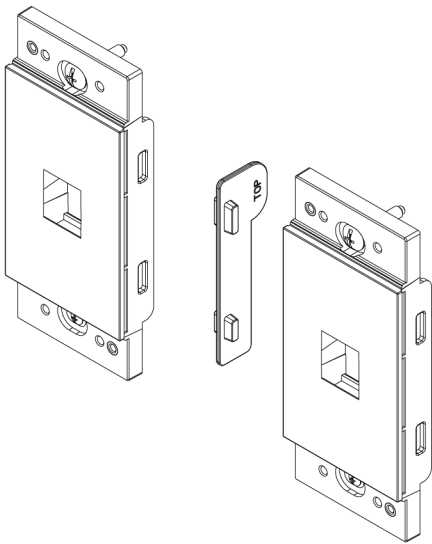

2. Secure the device to the electrical box using two #06-32 x 1 in. mounting screws (2054883). To allow for adjustments and installation of the metal bracket, do not fully tighten the mounting screws at this time. Ensure that any text on the device is in the proper orientation and facing up.

3. Place the top of the metal bracket (supplied with faceplate) over the back of the device and then insert the bottom of the metal bracket under the back of the device. Connect the top and bottom metal bracket by hanging the bottom bracket on the tabs on the top metal bracket. The two parts of the metal bracket clip together.

NOTE: If the electrical box extends beyond the wall, the metal bracket can be left off to prevent a gap between the wall and the faceplate.

4. Attach the rear of the faceplate to the device using two 04-40 x 0.25 in. screws (2050242). For multi-gang installations, use two screws per device. The rear of the faceplate provides access to the mounting screws.
5. Secure the rear of the faceplate to the metal backplate using four 04-40 x 0.25 in. screws (2050242).
6. Ensure that the device is properly aligned within the faceplate and then fully tighten the mounting screws to secure the device to the electrical box.

CAUTION: Do not overtighten the screws when attaching the device to the electrical box. Damage to the unit may occur.

7. Snap the faceplate onto the rear of the faceplate.

HZ2A-KEY Installation using 1-Gang Faceplate

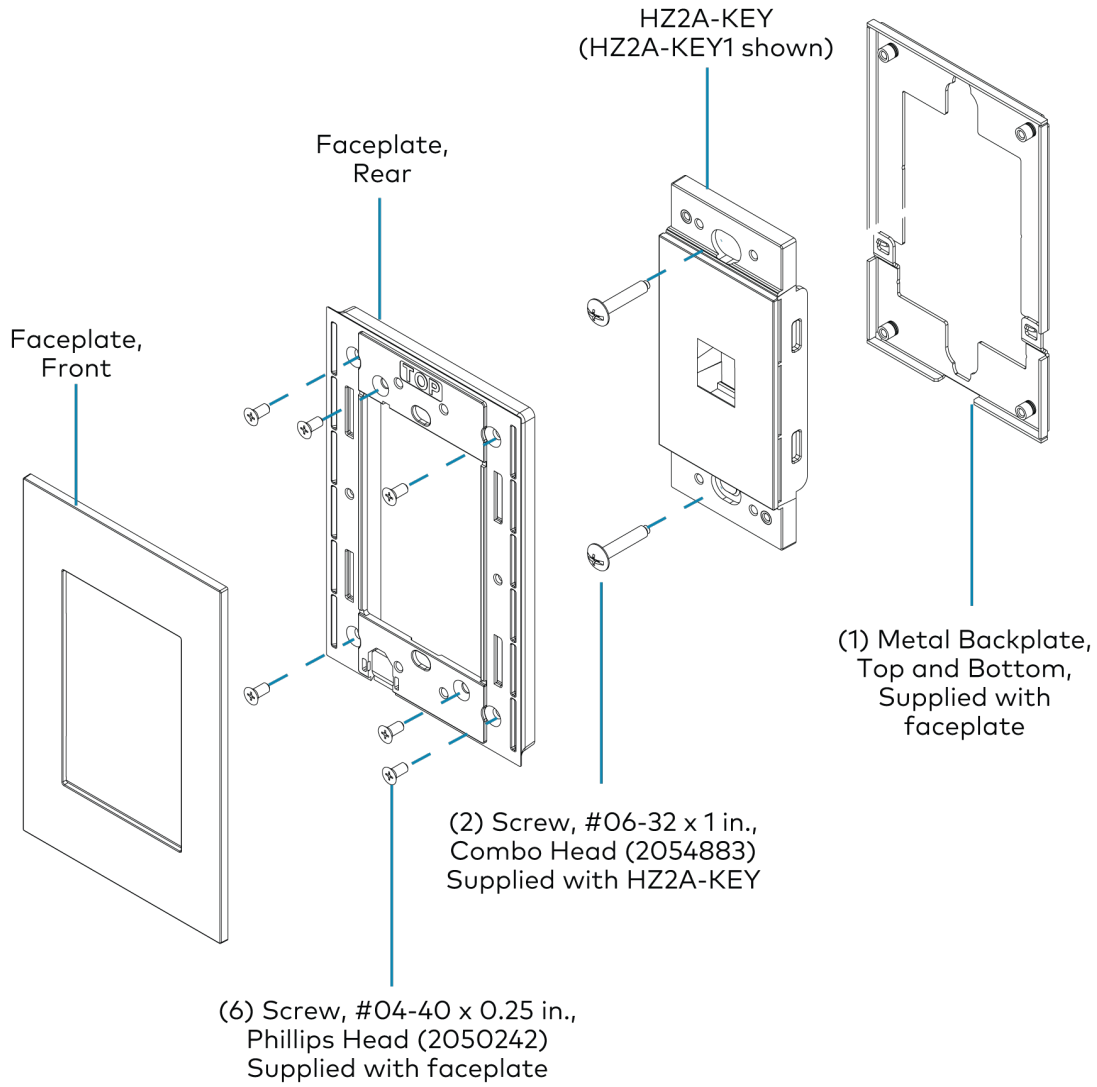

HZ2A-KEY Installation using 2-Gang Faceplate

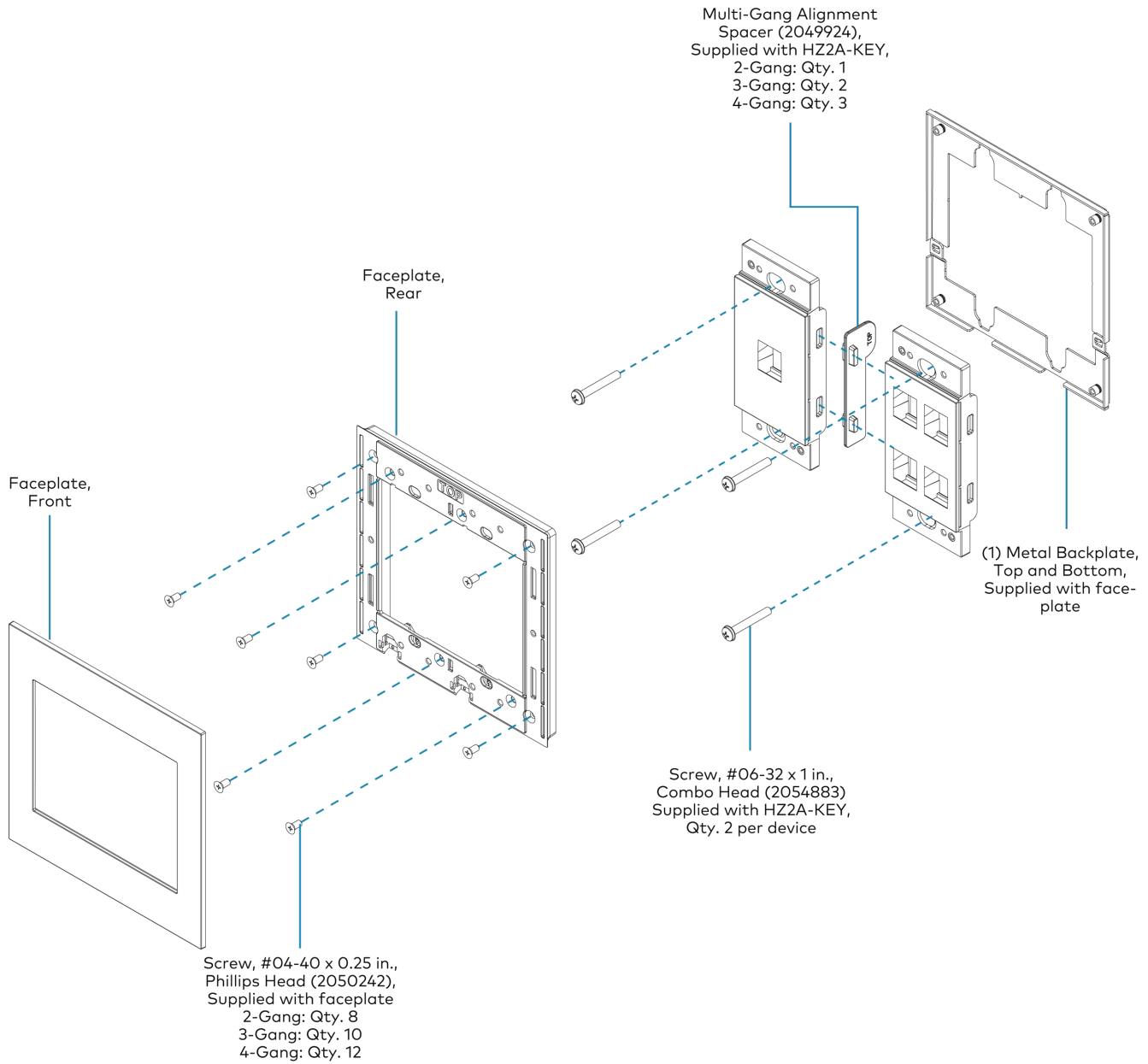

Post-Installation Metal Backplate Assembly

The two-piece metal bracket allows the wiring to remain in place if the backplate and faceplate are installed after the device is initially installed.

To install the two-piece metal backplate and faceplate after the device is installed:

1. Disconnect power to the device.
2. Loosen the two #06-32 x 1 in. mounting screws (2054883) that secure the device to allow space for the installation of the metal mounting bracket (supplied with faceplate). The screws need to be loosened enough to fit the metal backplate between the device and the wall.

3. Place the top of the metal bracket (supplied with faceplate) over the back of the device and then insert the bottom of the metal bracket under the device. Connect the top and bottom of the metal bracket by hanging the bottom of the bracket from the tabs on the top of the metal bracket.
4. Secure the device to the electrical box using two #06-32 x 1 in. mounting screws (2054883). Do not fully tighten the mounting screws at this time.
5. Attach the rear of the faceplate to the device using two 04-40 x 0.25 in. screws (2050242). For multi-gang installations, use two screws per device. The rear of the faceplate provides access to the mounting screws.
6. Secure the rear of the faceplate to the metal backplate using four 04-40 x 0.25 in. screws (2050242).
7. Ensure that the device is properly aligned within the faceplate and then fully tighten the mounting screws to secure the device to the electrical box.

CAUTION: Do not overtighten the screws when attaching the device to the electrical box. Damage to the unit may occur.

8. Snap the faceplate onto the rear of the faceplate.
9. Restore power to the device.

Multi-Gang Derating

Derating is required for multi-gang installations of the HZ2-DIMUEX and HZ2-DIMEX.

In multi-gang installations, several devices are grouped horizontally in one electrical box. For a smooth appearance, use a 2-, 3-, or 4-gang HZ2-FP-G series Horizon® 2 faceplate (not supplied). The load capacity for each device in the electrical box must be derated. Refer to the following diagrams for derating information. The VA ratings are for input power to the transformer. If you do not know the input power requirement of the transformer, use the bulb's wattage rating to determine the proper rating.

HZ-DIMUEX Derating

1-Gang Derating

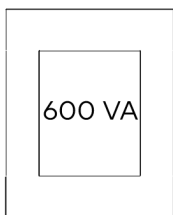

2-Gang Derating

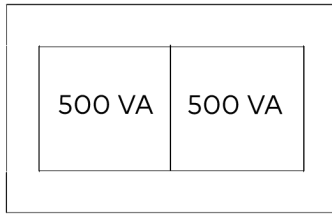

3-Gang Derating

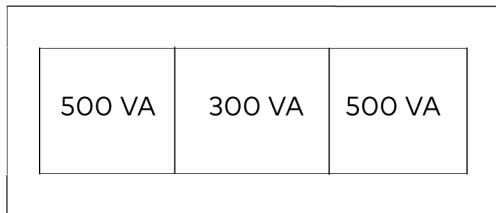

4-Gang Derating

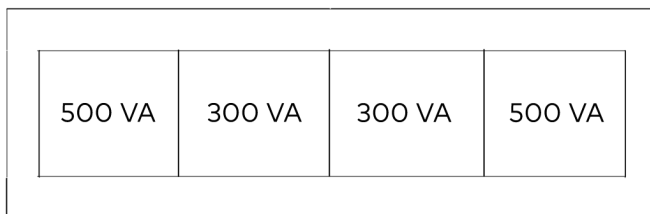

HZ-DIMEX Derating

1-Gang Derating

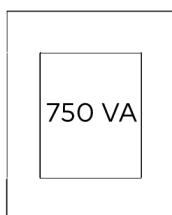

2-Gang Derating

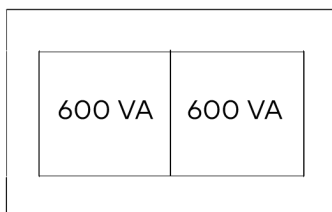

3-Gang Derating

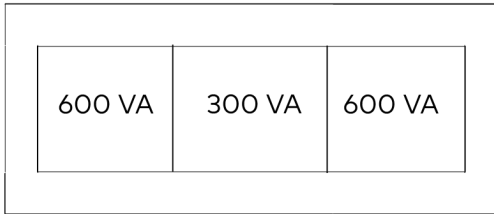

4-Gang Derating

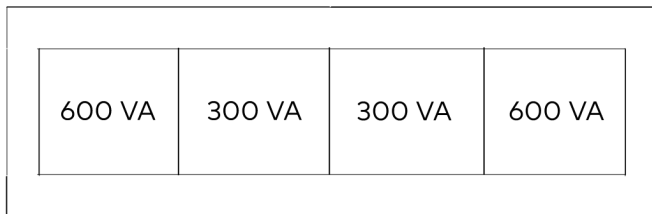
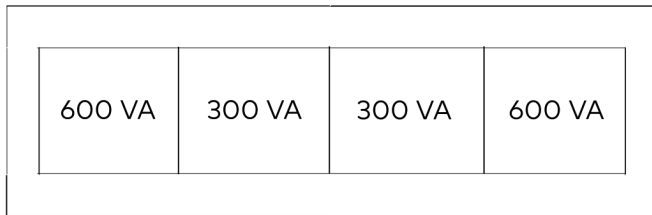

Wiring

Make connections to the line powered and 24VDC devices.

Line Powered Devices

To wire the Horizon® 2 device:

NOTE: To install the device, refer to [Mounting on page 86](#).

1. Turn power off at the circuit breaker.

WARNING: If the device is used with an HZ2-AUX or HZ2-KPEX, power may need to be turned off at multiple breakers.

2. Wire the device as shown in the following diagrams. In multigang installations, daisy-chain Hot and Neutral wires with other Horizon devices to eliminate excess wiring.
3. Fold the wires into the electrical box. Avoid pinched wires.

Proper Wiring Connections

No

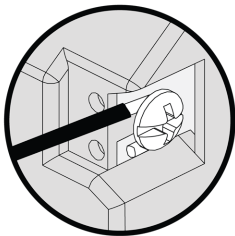

Yes

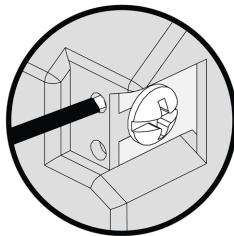

Do not insert the wires behind the screw head. Insert the wires into the wire entry holes.

HZ2-DIMEX, HZ2-DIMUEX, and HZ2-SWEX Wiring

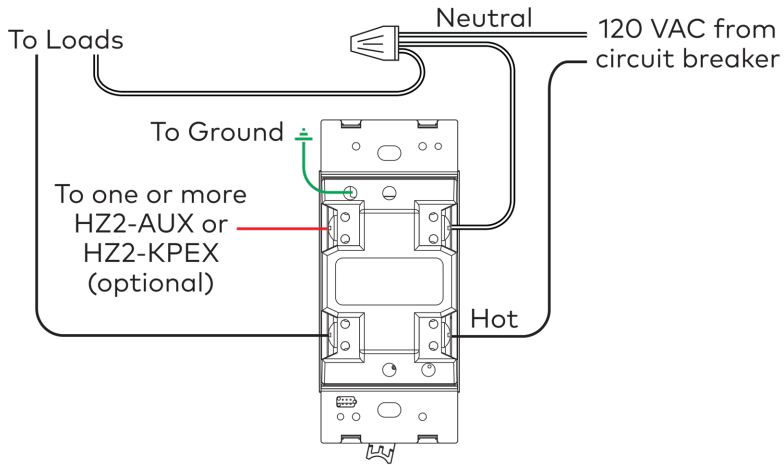

HZ2-DIMLVEX Wiring

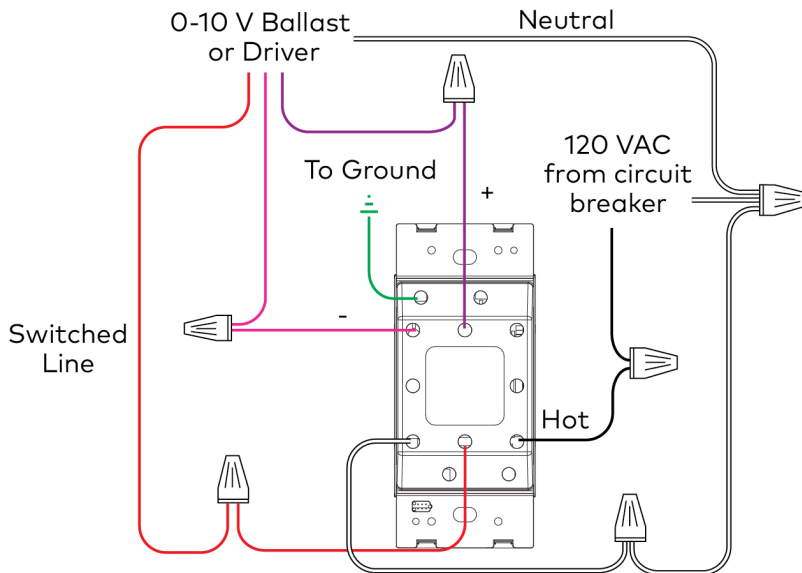

HZ2-KPEX Wiring

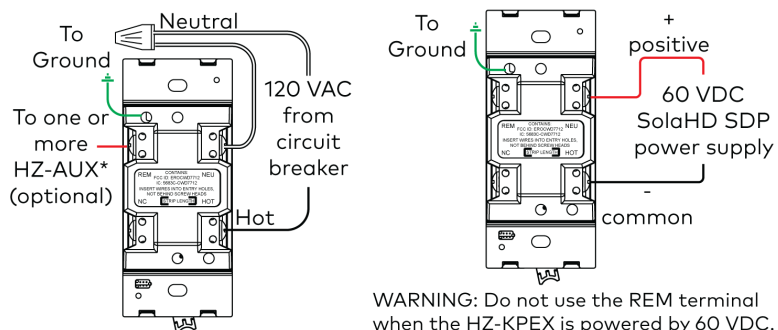

HZ2-AUX 3-Way Wiring

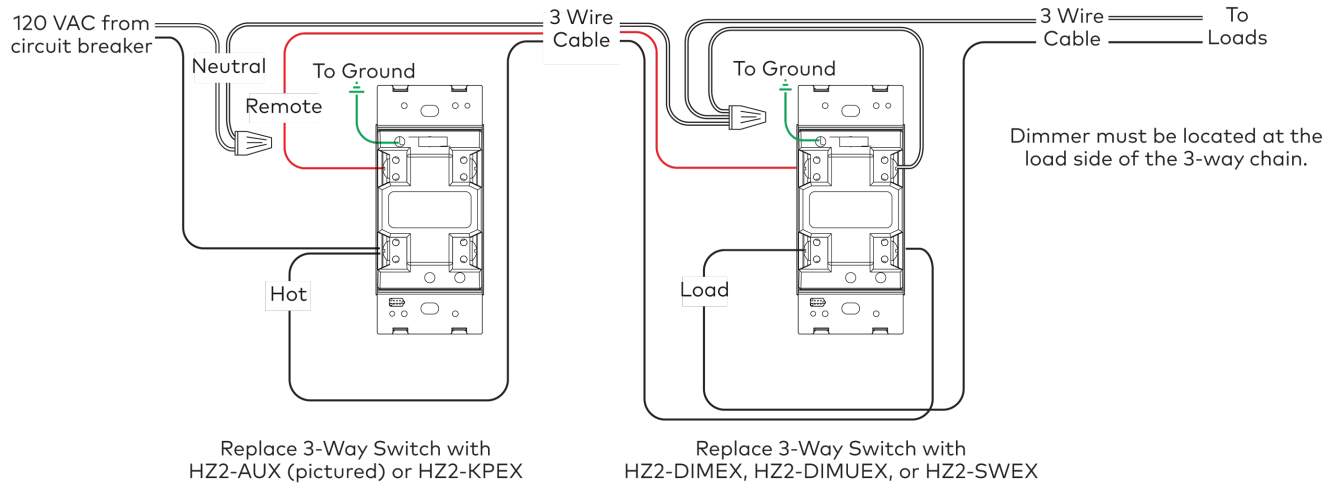

HZ2-AUX 4-Way Wiring

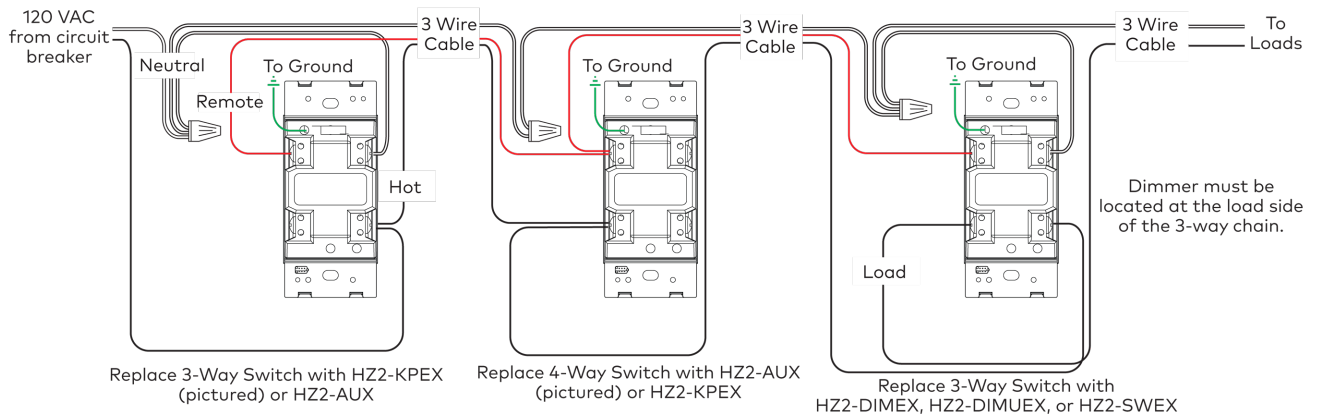

24VDC Powered Devices

The HZ2-KPCN is powered using 24VDC from the Cresnet® network cable.

To wire the HZ2-KPCN:

1. Make connections to the **INPUT** port. The port accepts connections from contact closures or non-system occupancy sensors.
2. Make connections to the **NET** ports. The ports accept 24V, Y, Z, and G connections from the Cresnet network. The ports provide pass-thru connection to daisy-chain additional Cresnet devices.

Button Assemblies

The keypad button layout is configurable to suit a wide range of uses. The keypad is configured using a variety of button assemblies. Button assemblies are intended to be laser-engraved to identify each button's function.

Replace Button Assemblies

CAUTION: Failure to follow the procedure outlined below may damage the button assembly.

To replace button assemblies:

1. Remove the front of the faceplate.
2. Remove the old button assembly using the flat end of a spudger:
 - a. Insert the spudger between the bottom of the button assembly and the keypad near the left edge of the button. Rotate the spudger tool counterclockwise to remove the left side of the button assembly. Continue towards the top until all snaps on the side are disengaged.
 - b. Insert the spudger between the bottom of the button assembly and the keypad near the right edge of the button. Rotate the spudger tool clockwise to remove the right side of the button assembly. Continue towards the top until all snaps on the side are disengaged.

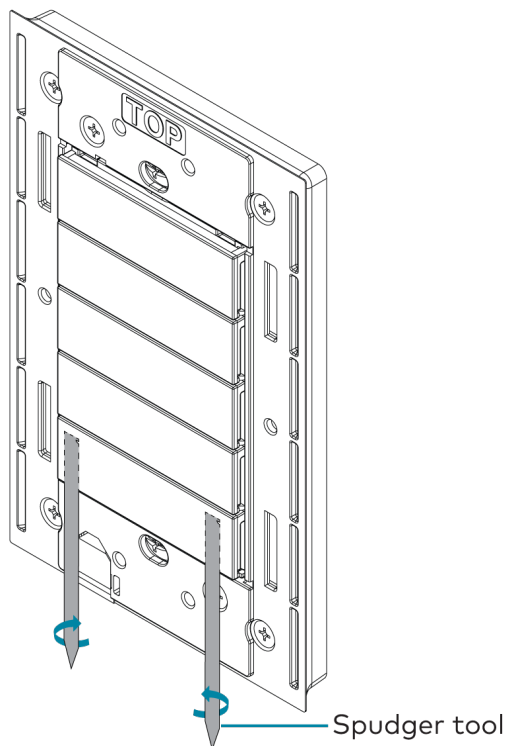

3. Align the posts on the back of the new button assembly with the slots in the keypad and then press the button assembly firmly onto the keypad until all snaps are engaged. Ensure that the

button assembly actuates without sticking.

4. Replace the front of the faceplate.

Local Button Functions

Most Horizon 2 keypads feature a Local Button function that provides control of the attached load that does not require a control system connection.

This function does not apply to the HZ2-KPCN and HZ2-AUX.

NOTE: One local button (a single or a rocker) can be assigned to the device.

The Local Button can be configured to trigger a function on the control system in addition to controlling the load. In this case, the LED feedback for the Local Button is dictated by the local load.

If desired, the local button can be disabled in the control system program. If the Local Button is disabled and communication with the control system is lost, the Local Button will be enabled and can provide control to the load.

The Local Button has the following default functionality:

- Rocker Button - Top or Right Position:
 - Single Press - On
 - Double Press - Fast On
 - Hold - Raise
- Rocker Button - Bottom or Left Position:
 - Single Press - Off
 - Double Press - Fast Off
 - Hold - Lower
- Single Button:
 - Single Press - Toggle On or Off
 - Double Press - No Function
 - Hold - Raise or Lower

NOTES:

- The HZ2-SWEX and dimmers set to non-dim mode do not have double press or hold functions for the Local Button. Each button press turns the load on or off.
- For dimmers, the default **On** powers the load to 100% in 1 second. The default **Fast On** powers the load to 100% in 1/4 second. Load behavior for **On** and **Fast On** operations can be modified when programming the device. The single push button can be designated as the local button in any of the five available positions.

Multiway Control from Remote Device

The HZ2-AUX and HZ2-KPEX recalls the functions defined on the connected load controller. The remote device does not directly control a load.

Configuration

Prior to configuration, ensure the device is running the latest firmware. Check for the latest firmware at www.crestron.com/firmware. Load the firmware onto the device using Crestron Toolbox™ software.

This section provides the following information:

- [Disconnect Power Locally](#)
- [Backlight Color Theme](#)
- [Ambient Light Sensor Calibration](#)
- [Dimming Mode](#)
- [Wireless Communications](#)
- [Demo Mode](#)

Disconnect Power Locally

Power to the device buttons, LEDs, and the connected load(s) can be disconnected by using the air-gap switch, which is located at the bottom of the HZ2-DIMEX, HZ2-DIMUEX, and HZ2-KPEX. Slide the air-gap switch to the right to disconnect power from the device buttons, LEDs, and the connected load. Slide the air-gap switch to the left to restore power.

NOTES:

- When the air-gap switch is in the right position, power is still supplied to the **HOT** terminal of the device.
- The air-gap switch must be in the left position for the device to operate.



Slide the air-gap switch to the right to shut off power to the unit and the load.

Backlight Color Theme

The backlight color theme can be adjusted locally or through programming.

NOTE: Custom and preset color themes may be defined in the control system program. Custom programming will override local settings.

To locally change the color theme of the LED backlights:

1. Press the setup button once with a small pointed object. The LED backlights will light brightly for 15 seconds.
2. Press the setup button repeatedly to cycle through the backlight color themes.

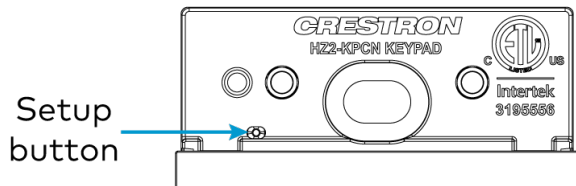

Ambient Light Sensor Calibration

An LED backlight behind each button illuminates engravings. The ambient light sensor adjusts the backlight brightness and switches the device between day and night operating modes according to the light level in the room. The ambient light sensor can be affected by room conditions and should be calibrated manually (locally or through programming) for the best user experience.

To locally calibrate the light sensor:

1. Ensure that all room lights are fully on.
2. Remove the front of the faceplate.

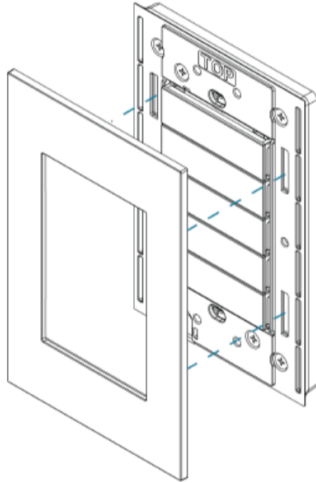

3. Press and hold the **setup** button with a small pointed object for about two seconds until all keypad backlights flash magenta. This can also be triggered in programming.

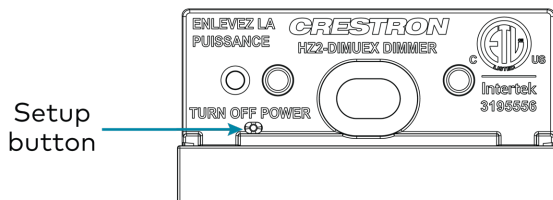

4. Avoid blocking or casting a shadow on the device and the wall/floor below it. The light sensor should remain unobstructed and free of direct light. After about five seconds, the calibration process is complete. The keypad returns to normal operation.

Preset ambient light sensor settings can also be selected in the control system programming if manual calibration is not an option. Preset sensor brightness descriptions are referring to the day/night threshold level. For example, **DARK** causes the device to switch to night mode at a darker ambient light level than **MEDIUM**. Ambient light levels are affected by wall color, flooring color, and nearby room features and furniture.

Dimming Mode

The HZ2-DIMEX and HZ2-DIMUEX keypads have multiple dimming modes. Refer to the sections below for information on changing modes.

HZ2-DIMEX

The HZ2-DIMEX can toggle between **Non-Dim** and **Dim** mode. In **Non-Dim** mode, the device acts as a switch. This is useful if the load is not dimmable or if it is preferred to not dim the load.

To switch between **Non-Dim** and **Dim** mode:

1. Slide the air-gap switch to the right to disconnect power. For details, refer to [Disconnect Power Locally on page 122](#).
2. With the power off, select a dimming mode.
 - **Non-Dim**: Press and hold the top button cap.
 - **Dim**: Press and hold the bottom button cap.

NOTE: If a side-to-side rocker is in the bottom position, either side of the rocker can be pressed and held.

3. While holding the appropriate button, slide the air-gap switch to the left and restore power to the device.
4. After all visible LEDs have flashed green once, release the button.
5. After the released button's LED flashes green, the device will boot up in the selected dimming mode.

HZ2-DIMUEX

By default, the HZ2-DIMUEX is set to **Auto Phase Dimming** mode, which allows the device to automatically toggle between forward and reverse phase dimming based on the connected load. The device can manually be set to **Auto Phase Dimming** mode or **Forward Phase Dimming** mode.

To switch between **Auto Phase Dimming** mode and **Forward Phase Dimming** mode:

1. Slide the air-gap switch to the right to disconnect power. For details, refer to [Disconnect Power Locally on page 122](#).
2. With the power off, select a dimming mode.
 - **Auto Phase Dimming**: Press and hold the top button cap.
 - **Forward Phase Dimming**: Press and hold the bottom button cap.

NOTE: If a side-to-side rocker is in the bottom position, either side of the rocker can be pressed and held.

3. While holding the appropriate button, slide the air-gap switch to the left and restore power to the device.
4. After all visible LEDs have flashed green once, release the button.

NOTE: If the dimming mode has already been set via programming, the LEDs will flash red five times and the new mode will not be set. To modify the parameter, change the setting in control system programming to "Local Settings" and retry the operation.

5. After the released button's LED flashes green, the device will boot up in the selected dimming mode.

Wireless Communications

The device connects to the Crestron network via the infiNET EX communications protocol. Use the following procedures to join or leave an infiNET EX network and to verify communications between the device and the control system.

NOTE: The device is not compatible with the [MC3](#) internal gateway when using channels 25 or 26.

Joining an infiNET EX Network

Before a device can be used in a lighting system, it must first join an infiNET EX network by being acquired by an infiNET EX gateway.

NOTE: A device can be acquired by only one gateway.

1. Put the infiNET EX gateway into **Acquire** mode from the unit itself or from Crestron Toolbox software, as described in the [gateway's manual](#).

NOTE: In an environment with multiple gateways, only one gateway should be in **Acquire** mode at any time.

2. Place the device into **Acquire** mode.
 - a. Tap the top button three times and then press and hold it down (tap-tap-tap-press+hold) until all of the LEDs flash red once. This can take up to ten seconds if the device has been previously acquired to a gateway.
 - b. Release the button to start the acquire process. The top button's LED flashes red slowly to show that the device is actively scanning the infiNET EX network.
 - The top button's LED lights red for five seconds to show that the device has been successfully acquired to the infiNET EX network.
 - The top button's LED flashes red quickly to indicate that the device was not successfully acquired by the infiNET EX network. Tap the setup button to acknowledge failure to acquire the infiNET EX network. Before attempting the acquire process again, ensure one of the following:
 - The gateway is in Acquire mode and within range.
 - A non-battery powered infiNET EX device is in **Acquire** mode on the same gateway.
3. Once all devices have been acquired, take the gateway out of **Acquire** mode. For details, refer to the gateway's manual.

Leaving an infiNET EX Network

To leave an infiNET EX network, put the device into **Acquire** mode. Ensure that no gateway is in **Acquire** mode when removing a device from an infiNET EX network.

To place the device into Acquire mode, refer to [Joining an infiNET EX Network on page 127](#).

Verifying Communications Status

To check the communications status of the device, tap the top button three times and then press and hold it down (tap-tap-tap-press+hold) for up to two seconds. The button must be released before the LEDs flash to indicate the communications status. Refer to the following table for details.

NOTE: If there is a communication error and a remote button is pressed, all of the LEDs will flash red in one of the patterns described in the table below.

LED	Communication Status
Turns on for five seconds	The device is communicating with the control system.
Flashes three times	The device is communicating with the gateway, but the gateway is not communicating with the control system.
Flashes twice	The device was previously joined to the network but is not communicating with the gateway.
Flashes once	The device is not joined to the network.

Demo Mode

The HZ2-KPCN offers a demo mode that highlights various features of the keypad.

Entering and Exiting

To enter demo mode, perform the following sequence with the Setup button located under the faceplate: tap, tap, tap, and hold. The LED blinks green to signify demo mode has started.

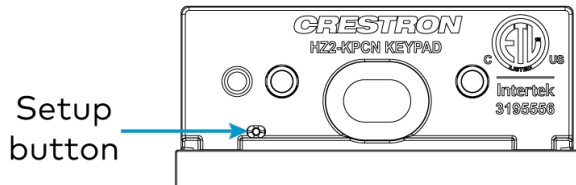

NOTES:

- Demo mode should not be used when the keypad is part of a control processor program.
- The device will remember which demo mode option it is in through a power cycle.

To exit demo mode, repeat the sequence. The LED blinks red to signify demo mode has ended.

Demo Mode Options

There are five options in demo mode. Each option changes some or all of the following:

- Behavior of the backlight
- What happens when a button is pressed, referred to in this section as indication.
- Color theme. For information on color themes, refer to [Backlight Color Theme on page 123](#).

The keypad begins in option one. To switch options, press and hold the associated button for three seconds. The backlight flashes blue to announce an option switch.

NOTE: When using a large or medium rocker, the button assembly may need to be removed to access all of the demo mode options.

- **Option One:** Top Button
 - Backlight stays off during day mode and turns on during night mode. This mimics the default behavior of the keypad.
 - During day mode, indication is provided as on or off. Night indication is brighter than the backlight.
 - Pressing the Setup button cycles the backlight and indication color themes.
 - Pushing any button toggles that button position between indication and backlight.

- **Option Two:** Second Button from the Top
 - Backlight is on in both day mode and night mode.
 - Indication is brighter than the backlight.
 - Pressing the Setup button cycles the backlight and indication color themes.
 - Pushing any button toggles that button position between indication and backlight.
- **Option Three:** Middle Button
 - Backlight is on in both day mode and night mode.
 - Indication is the same brightness as the backlight in a different color.
 - Backlight color is always cool white
 - Indication color defaults to cyan. Pressing the Setup button cycles the indication color theme.
 - Pushing any button toggles that button position between indication and backlight.
- **Option Four:** Second Button from the Bottom
 - Backlight cycles slowly from warm white to cool white and then back to warm white in a continuous smooth loop.
 - Buttons have no function in this demo mode
- **Option Five:** Bottom Button
 - Backlight cycles through all fully saturated colors then warm/cool white in a continuous smooth loop.
 - Buttons have no function in this demo mode

Troubleshooting

The module displays error codes using the output LEDs. The LED flashes a pattern to indicate the error on that output. For example, a 2-1 error flashes the LED two times, pauses for one second, flashes once, pauses for two seconds, and then repeats for 90 seconds (except where otherwise noted). Refer to the following table for possible corrections.

Error Code	Fault Name	Fault Description
2-1	Over Current	A short circuit has been detected. Verify that there are no shorts in the wiring and that the total load output matches the proper ganged ratings.
2-2	Shorted FET	A flowing current is detected when an FET should be off. The load will power to 100%. This error code is permanent until the device is power cycled. Disconnect the load and contact Crestron Technical Support .
2-3	Over Temperature	The dimmer has overheated and shut down due to an excessive load. Verify that the total load matches the proper ganged rating. The dimmer resumes normal operation after cooling.
2-4	Over Voltage	High voltage spikes have been detected and output has been shut down. If a magnetic load is connected, verify that the dimming phase has been set to Forward Phase mode.
2-5	Overload	A load is detected beyond the allowable load rating. This error code will cause the device to shut down. Verify that the total load output matches the proper ganged rating.
3-1	Zero Cross Fault	The dimmer is unable to lock onto the AC line. If the unit is powered by a generator, verify that the generator output is 50/60 Hz and stable.
3-3	Device Error	The device is experiencing a hardware issue. Please contact Crestron Technical Support .

For general troubleshooting, refer to the following table.

Trouble	Probable Cause(s)	Corrective Action
The device does not function. No LEDs turn on when a button is pressed.	The device is not receiving power.	Verify that the power connections are correct and that the circuit breaker is closed.
	The neutral wire is not connected to the device.	Connect a dedicated neutral wire to the device.
	The air-gap is open.	Ensure that the air-gap is switched to the left.

Trouble	Probable Cause(s)	Corrective Action
The device does not function. All LEDs flash when a button is pressed.	The keypad is not acquired by a gateway.	Perform the acquire process.
The device does not function. All LEDs flash three times when a button is pressed.	The keypad is not communicating with the gateway.	Ensure that the gateway is powered. Ensure that the keypad is within range of the gateway or other infiNET EX devices.
The LEDs do not light.	The LEDs are not enabled.	Ensure the LEDs have not been disabled in programming.
The backlight LEDs are too dim.	Day/Night Threshold is not set correctly.	Ensure that calibration has been completed or select a darker preset Day/Night Threshold. For details, refer to Ambient Light Sensor Calibration on page 124 .
	Default brightness levels may not be appropriate for the install location.	Raise the Manual Brightness setting.
The backlight is off when the room is bright, but turns on when the room is dim.	The backlight being off in a bright room is the default operating mode. This ensures a good user experience in the largest number of install conditions.	For the backlight to be on even in a bright room, the Manual Brightness for Day Off needs to be set to a non-zero value. If using the same color for backlight and feedback, this value should be set to around 60% of the Day On level for sufficient contrast. If using a different color for backlight and feedback, this value can be set as high as the Day On value for improved visibility.

For troubleshooting on specific models, refer to the following table.

Trouble	Probable Cause(s)	Corrective Action
HZ-DIMEX: The dimmer does not dim.	The device is in Non-Dim mode.	Remove power from the device. Press and hold the bottom button and reapply power. Continue holding the bottom button until all LEDs flash green once.
HZ-DIMUEX: The dimmer does not dim to a low level or flickers when dimmed.	The lamps connected may be better suited to an alternate dimming mode.	Switch the dimmer to an alternate dimming mode.
		Adjust the minimum dim level. Contact Crestron Technical Support .

Trouble	Probable Cause(s)	Corrective Action
HZ-KPEX and HZ-AUX: Primary device does not function when buttons are pressed on the primary or the KPEX/AUX device.	Problem with primary device installation.	Troubleshoot the primary device.
	Existing 3- or 4-way switch still connected.	Replace 3- or 4-way switches with an HZ-KPEX or an HZ-AUX. Replace the 3-way switch connected to the load with an HZ-DIMEX, HZ-DIMUEX, or HZ-SWEX.
HZ-KPEX and HZ-AUX: Primary device works but the KPEX/AUX button press does not work.	Wiring issue.	Check connections on all multiway units and on primary dimmer.
	Existing 3- or 4-way switch still connected.	Replace 3- or 4-way switches with an HZ-KPEX or an HZ-AUX. Replace the 3-way switch connected to the load with an HZ-DIMEX, HZ-DIMUEX, or HZ-SWEX.

Resources

The following resources are provided for Horizon 2 devices.

NOTE: You may need to provide your Crestron.com web account credentials when prompted to access some of the following resources.

Crestron Support and Training

- [Crestron True Blue Support](#)
- [Crestron Resource Library](#)
- [Crestron Online Help \(OLH\)](#)
- [Crestron Training Institute \(CTI\) Portal](#)

Programmer and Developer Resources

- help.crestron.com: Provides help files for Crestron programming tools such as SIMPL, SIMPL#, and Crestron Toolbox™ software
- developer.crestron.com: Provides developer documentation for Crestron APIs, SDKs, and other development tools

Product Certificates

To search for product certificates, refer to support.crestron.com/app/certificates.

