

UC-B70-A-T

Crestron Flex Large Room Conference Solution with All-In-One Videobar 70 for Microsoft Teams® Rooms



- *Front-of-room video conferencing solution for Microsoft Teams® Rooms*
- *Intelligent high-definition video, immersive high-quality audio, built-in digital signal processor, and Microsoft Teams Rooms conferencing software, all in one Android™ OS-based Crestron Videobar 70 enclosure*
- *Native Microsoft Teams® Rooms Controller touch screen UI provides a consistent, simple user experience with one-touch meeting joins*
- *Complete kit contains a 10 in. tabletop touch screen, all-in-one Crestron Videobar 70 with tilting wall bracket, and a PoE injector.*
- *Easy to deploy and install – no custom design, programming, or software installation required*
- *Network management and provisioning and system alerts through the XiO Cloud® service*
- *Enterprise-grade security – connects and communicates securely over any enterprise or SMB (Server Message Block) network*
- *Supports video displays (not included)*

The UC-B70-A-T Crestron Flex tabletop conferencing system provides a medium to large room video conference solution for use with Microsoft Teams® Rooms. It simplifies the communications and collaboration needs with fewer components and maximum efficiency. The UC-B70-A-T features a 10 in. tabletop touch screen, Crestron Videobar 70 with intelligent high-definition video and audio, a PoE injector, and cables. The UC-B70-A-T also supports up to two video displays¹ (not included).

The UC-B70-A-T conferencing solution delivers a hassle-free setup and installation, better space utilization, a cleaner and visually appealing environment, easy collaboration and content sharing, and scalable deployment.

High-Definition Video Conferencing

The powerful and elegant all-in-one (AIO) Crestron Videobar 70 provides a convenient and compact conferencing solution for medium to large-sized meeting rooms. It comprises:

- A quad-camera setup that captures the full room in 4K, automatically tracks and frames the presenter or everyone in the room based on its configuration, and enhances video content using AI.
- 10-watt dual speakers produce full, rich, and natural-sounding audio. Additional digital signal processing with AEC and noise reduction assures optimal sound quality for an immersive experience.
- Integrated 24-microphone array to capture voices throughout the room using adaptive beamforming technology. AI noise cancellation is also provided to ensure crystal-clear communication with exceptional audio fidelity and pickup.
- Android™ OS running on the QCS8250 chipset that ensures a smooth and reliable conferencing experience every time.

Native Microsoft Teams® Rooms Experience

The UC-B70-A-T system brings the full Microsoft Teams Rooms UC experience to any meeting space in an enterprise or SMB facility.

Android OS-Based Conferencing System

As an Android OS-based conferencing system, the UC-B70-A-T provides a consistent, secure Microsoft Teams® Rooms experience. The system's tabletop controller and Videobar 70 both run on Android OS to ensure compliance with enterprise requirements.

Intuitive User Interface

With a large 10 in. (254 mm) capacitive touch screen display, the Crestron® tabletop touch screen ([TS-1070](#)) provides superior conferencing control in meeting rooms, huddle spaces, and executive offices.

Simplified Deployment

The AIO Crestron Videobar 70 comes with one ready-to-mount wall bracket allowing the video bar to install cleanly beneath the display – connect the display, touch screen and mount.

Enterprise-Grade Security

Crestron Flex is an enterprise-grade solution is equipped for mass deployment throughout any sized corporate, university, medical, military, or government facility.

Easy Provisioning and Device Management

The XiO Cloud® service is an IoT cloud-based provisioning service (available separately) that enables installers and IT managers to easily deploy and manage thousands of devices. The XiO Cloud service provides system alerts, network management and provisioning, and pairing of a control device to the Crestron Videobar 70. System updates are controlled by Windows® software update.

Visit www.crestron.com/xiocloud for additional information.

UC-B70-A-T

Crestron Flex Large Room Conference Solution with All-In-One Videobar 70 for Microsoft Teams® Rooms

Premium-Level Support

Crestron Flex Care is an optional subscription service that automatically renews annually, providing 24/7 live remote technical support, an extended five year warranty on Crestron® branded hardware, expedited advance replacements, and a discounted rate for onsite support.

Visit www.crestron.com/flexcare for detailed terms and conditions and additional information.

Specifications

Included Components

TS-1070-B-S-T-A	10 in. (254 mm) tabletop touch screen, black
UC-SB2-CAM-A-T	Crestron Videobar 70
CBL-CAT5E-7	Ethernet LAN cable for UC Engine, RJ-45-to-RJ-45, black, 7 ft (2.1 m)
CBL-8K-HD-6	(2) HDMI® 2.1 Cable, 6 ft (1.8 m)
CBL-8K-HD-22	HDMI 2.1 Cable, 22 ft (6.7 m)
DM-CBL-ULTRA-PC-20	Ethernet LAN cable, CAT6a, RJ-45-to-RJ-45, blue, 20 ft (6.1 m)
PWE-4803RU	PoE Injector

Tabletop Touch Screen

Touch Screen	10 in. (254 mm) diagonal capacitive multi-touch TFT active matrix color LCD, 1920 x 1200 pixels
Ethernet	100/1000 Mbps, autoswitching, autonegotiating, autodiscovery, full/half duplex, TCP/IP, UDP/IP, CIP, DHCP, SSL, TLS, SSH, SFTP (SSH File Transfer Protocol), IEEE 802.1X, SNMP, IPv4 or IPv6, Active Directory® service authentication, HTTPS web browser setup, XiO Cloud® client, IEEE 802.3at compliant
Power over Ethernet	IEEE 802.3at Type 2 compliant PoE+ PD (Powered Device); Normally requests 15 W from an 802.3at Type 2 PSE with LLDP advanced power management; With room scheduling and USB enabled, requests 18 W from an 802.3at Type 2 PSE with LLDP; Requests 30 W (PoE+ Class 4) from an 802.3at Type 2 PSE without LLDP; Requests 15.4 W (PoE Class 0) from an 802.3af (or 802.3at Type 1) PSE
Construction	Plastic, smooth black finish, edge-to-edge glass with black surround

Dimensions	Height: 5.29 in. (134 mm) Width: 9.63 in. (245 mm) Depth: 4.67 in. (119 mm)
Weight	2.44 lb (1.10 kg)

Crestron Videobar 70

Speakers	Dual 10-watt speakers
Microphone	24 mic linear array

NOTE: Microphone pickup range may vary in rooms with highly reflective infrastructure (e.g., glass walls, metal furniture, open ceilings, etc.) or above average ambient noise.

Audio DSP	Acoustic echo cancellation, dereverberation, automatic gain control, dynamic noise suppression, adaptive beamforming, speaker volume control, speaker EQ and limiting (fixed);
Quad Camera Configuration	(1) Main camera; (1) Left, (1) center, and (1) right sub cameras with 14° overlap
Main Camera Optics	Main camera 20 Megapixels 1 in. sensor
Camera Field of View	Main Camera: 84.3° horizontal, 53.8° vertical; Left, center and right sub cameras: 41° horizontal, 23° vertical
Camera Resolution	Main Camera: 5472 x 3078 pixels; Left, center and right sub camera: 3840 x 2160 pixels
Autozoom	7.5x digital zoom
Camera Shutter	Mechanical, electronically controlled
Operating System	Android OS running on the QCS8250 chipset
Memory	LPDDR5 12GB; UFS 128GB
Connectivity	100/1000 Mbps Ethernet connectivity
Wi-Fi® Connectivity	Dual Band Simultaneous Wi-Fi 6 2x2 80 MHz
Bluetooth® Connectivity	Bluetooth 5.2 (for future use)
UC Client	Microsoft Teams® Rooms
Management Client	XiO Cloud Service
Content Ingest	HDMI input on Crestron Videobar 70 or direct sharing
Display Output	Up to two displays supported

UC-B70-A-T

Crestron Flex Large Room Conference Solution with All-In-One Videobar 70 for Microsoft Teams® Rooms

Display Output Resolution	(2) 4K
Video Input Signal Types	HDMI, 1080p 30
Video Output Signal Types	HDMI, 4K30
Video Content Protection	HDCP 1.4 and HDCP 2.2
Audio Input Signal Types	HDMI: Two-channel LPCM
Connectors	HDMI port: (2) HDMI In (Input 2 reserved for future use), (3) HDMI Out (Output 3 reserved for future use); 3.5 mm Line in / Line out: (1) Audio In, (reserved for future use) (1) Audio Out (reserved for future use); LAN: (2) 8-pin RJ-45 connector; USB A: (2) USB 3.0 Type A connector (reserved for future use); USB C: (2) USB 3.1 Type-C connector (reserved for future use)
Input Power	19VDC via external 100-240VAC, 50/60 Hz power pack (included)
Temperature	32° to 104°F (0° to 40°C)
Enclosure	Plastic, smooth black finish; Speaker and camera housing, rear air vents, integrated mounting bracket
LED Indicators	Green indicates microphones are unmuted; Red indicates microphones are muted
Mounting	Wall mount using integrated mounting bracket, optional desktop stand and display bracket accessories
Dimensions	Height: 4.33 in. (110 mm); 6.38 in. (162 mm) with bracket; Length: 38.58 in. (980 mm) Depth: 3.77 in. (96 mm); 4 in. (101 mm) with bracket
Weight	13.2 lb (6 kg)

Notes:

1. Display must support "Wake on Sync" and "Sleep on No Sync" functionality. Consult the display manufacturer's specifications or internal settings of the specific display.

This product may be purchased from select authorized Crestron dealers and distributors. To find a dealer or distributor, please contact the Crestron sales representative for your area. A list of sales representatives is available online at www.crestron.com/How-To-Buy/Find-a-Representative or contact us for additional information by visiting www.crestron.com/contact/our-locations for your local contact.

The original language version of this document is U.S. English. All other languages are a translation of the original document.

The product warranty can be found at www.crestron.com/warranty.

The specific patents that cover Crestron products are listed online at www.crestron.com/legal/patents.

Certain Crestron products contain open source software. For specific information, please visit www.crestron.com/opensource.

Crestron, the Crestron logo, and XiO Cloud are either trademarks or registered trademarks of Crestron Electronics, Inc. in the United States and/or other countries. Bluetooth is either a trademark or registered trademark of Bluetooth SIG, Inc. in the United States and/or other countries. Android is either a trademark or registered trademark of Google Inc. in the United States and/or other countries. HDMI and HDMI logo is either a trademark or registered trademark of HDMI Licensing LLC in the United States and/or other countries. Active Directory, Microsoft Teams and Windows are either trademarks or registered trademarks of Microsoft Corporation in the United States and/or other countries. Wi-Fi is either a trademark or registered trademark of Wi-Fi Alliance in the United States and/or other countries. Other trademarks, registered trademarks, and trade names may be used in this document to refer to either the entities claiming the marks and names or their products. Crestron disclaims any proprietary interest in the marks and names of others. Crestron is not responsible for errors in typography or photography.

HDMI

Specifications are subject to change without notice.

©2024 Crestron Electronics, Inc.

Rev 09/26/24

Model

UC-B70-A-T

Crestron Flex Large Room Conference Solution with All-In-One Videobar 70 for Microsoft Teams Rooms

Available Accessories

For a list of available accessories, visit the [UC-B70-A-T](http://www.crestron.com/UC-B70-A-T) product page.

UC-B70-A-T

Crestron Flex Large Room Conference Solution with All-In-One Videobar 70 for Microsoft Teams® Rooms

UC-SB2-CAM-A-T

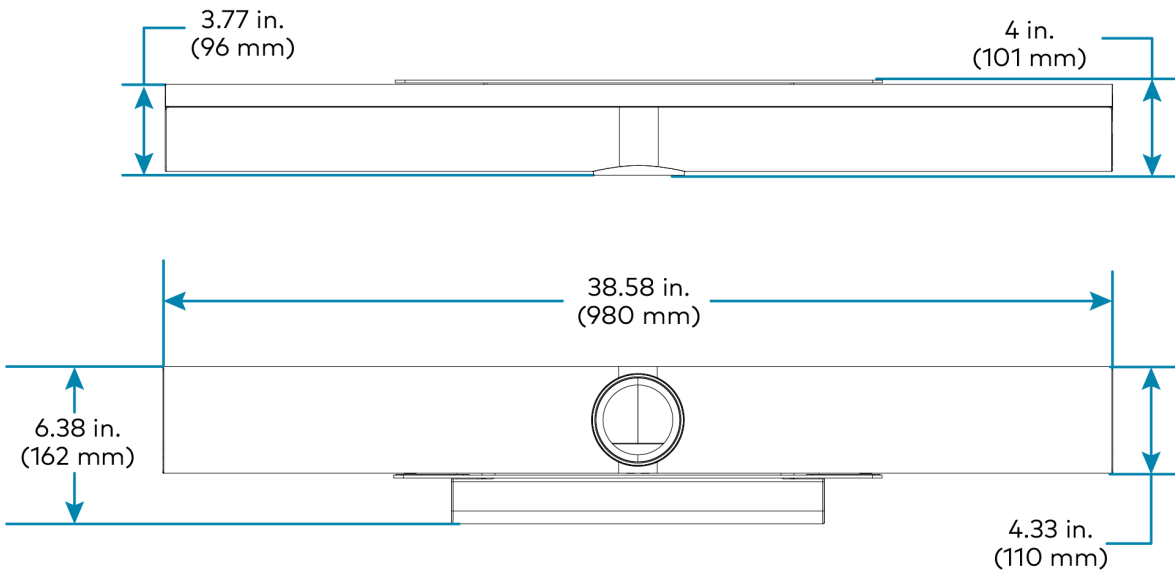

UC-B70-A-T

Crestron Flex Large Room Conference Solution with All-In-One Videobar 70 for Microsoft Teams® Rooms

Touch Screen (TS-1070-B-S-T-A)

